

PITHAPUR RAJAH'S GOVERNMENT COLLEGE (A)

KAKINADA

Affiliated to Adikavi Nannaya University

Rajamahendravaram

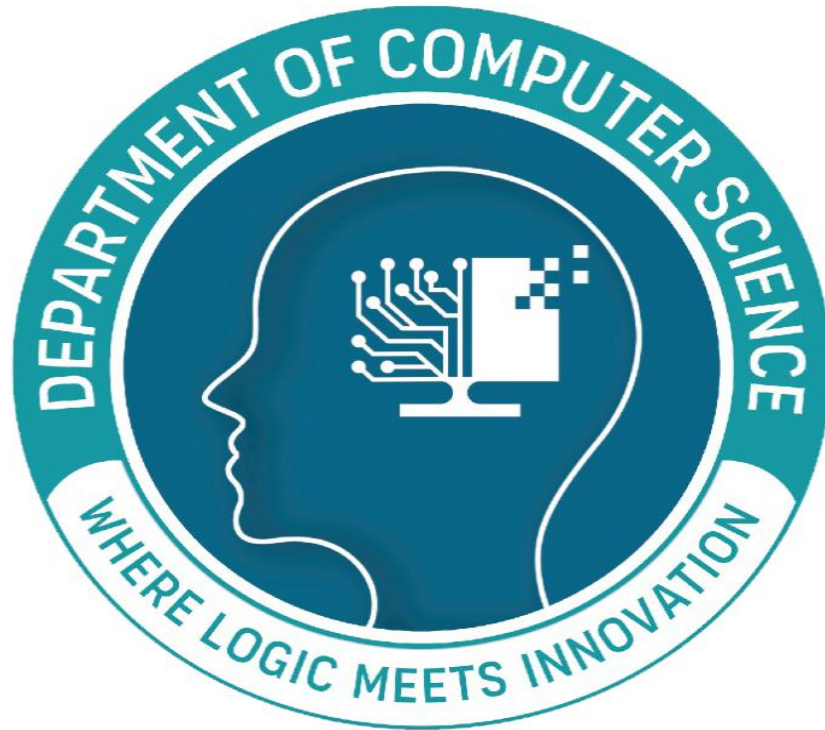

DEPARTMENT OF COMPUTER SCIENCE

BOARD OF STUDIES

2025-2026

Programme: Data Science (Single Major)

BOS COMPOSITION
PROCEEDINGS OF THE PRINCIPAL (FAC), P.R. GOVERNMENT COLLEGE (A),
KAKINADA

Present: Dr. Kandula Anjaneyulu, M.A, Ph.D.

R.C.No.2/A.C/BOS - Members Nomination/2025-26

Dated: 31.07.2025

SUB: P.R. Government College (A), Kakinada - UG Board of Studies (BOS) - Nomination of Members - Orders issued.

REF: Proc.RC.No.1/A.C/BOS/2025-26 dated: 31 July 2025 of the Principal, Pithapur Rajah's Government College (A) Kakinada.

ORDER:

The Principal, P.R. Government College(A), Kakinada is pleased to constitute UG Boards of Studies in **B.Sc. Data Science** for framing the syllabi in respective Subjects for all semesters duly following the norms of the UGC Autonomous guidelines.

S. No	Name of the Person	Designation
1	Sri. R V Satyanarayana	Chairman & Lecturer Incharge, Department of Computer Science
2	Sri. K Rasmi Ranjan, Lecturer in Computer Science, GDC(A), Tuni.	University Nominee
3	Smt.N Naga Subrahmanyeswari, Lecturer in Computer Science, ASD College for Women (A), Kakinada	Subject Expert-1
4	Sri. N. Gopala Krishna, Lecturer in Computer Science, GDC, Mondapeta.	Subject Expert-2
5	Sri. P Swamy Vandanam, Managing Director, BDPS Computers, Kakinada	Representative from Industry
6	Sri. A Anantha Teja, Lecturer in Computer Science	Member
7	Ms. Peruri Susmitha, Lecturer in Computer Science	Member
8	Sri. Chinta Moses Raju, Lecturer in Computer Science	Member
9	Mrs. M Varalakshmi, Lecturer in Computer Science	Member
10	MS. J Lakshmi Gayatri, Lecturer in Computer Science	Member
11	Sri. P A Sai Ganesh, Lecturer in Computer Science	Member
13	Sri. Sakala Apparao, Consultant, Cap Gemini	Student Alumni Member
14	Devarakonda Bhuvaneshwari, II B.Sc. (DS)	Student Member
15	Rongali Jagadeesh, II B.Sc. (DS)	Student Member

The above members are requested to attend the BoS meeting on 12-08-2025 FN and share their valuable reviews, and suggestions on the following functionaries.

- Prepare syllabi for the subject keeping in view the objectives of the college and interest of the stake holders for consideration and approval of the IQAC and Academic Council.
- Suggested methodologies for innovative teaching and evaluation techniques.
- Suggest the panel of Names to the academic council for appointment of Examiners.
- Coordinate research, teaching, extension and other activities in the Department.

PRINCIPAL
P.R. Govt. College (Autonomous)
KAKINADA-533 001.

Vision and Mission of the Department

Vision:

To be a premier destination for computer science education and innovation, dedicated to shaping highly employable and socially responsible professionals who drive technological progress and positive change.

Mission:

- **Quality Education:** To provide a rigorous, current computer science curriculum that builds strong theoretical and practical skills for professional growth.
- **Techno-savvy Students:** To enhance critical thinking, creativity, and problem-solving to prepare students for real-world challenges.
- **Industry-Academia Collaboration:** To collaborate with industry leaders to offer internships and apprenticeships, making students industry-ready.
- **Social Responsibility:** To encourage ethical practices and societal contributions, guiding students to address global challenges.

P. R. Government College (Autonomous), Kakinada
Department of Computer Science
Board of Studies 2025-26 (Data Science Program)

The Meeting of the **Board of Studies in Data Science** was held in the Department of Computer Science on **12 August 2025 FN** to deliberate on the following agenda items:

AGENDA

- 1. Implementation of Pedagogical Practices** – Framing course objectives and outcomes, preparing syllabus blueprints, model question papers, and adopting innovative teaching–learning methodologies (ICT tools, project-based learning, blended learning, etc.) for effective delivery of curriculum in the **Data Science Program**.
- 2. Departmental Academic Activities (2025–26)** – Planning of seminars, workshops, conferences, training programs, faculty development programs (FDPs), and student development initiatives.
- 3. Curriculum Revision and Updation** – Review and necessary modifications of the existing syllabi in **Data Science**
- 4. Adoption of APSCHE Model Curriculum** – Implementation of APSCHE-prescribed curriculum for I Year students with effect from the academic year 2025–26.
- 5. Assessment and Evaluation Methods** – Approval of the following pattern:
 - Internal Assessment: **50% weightage** for I, II, and III Year students.
 - End Semester Examinations: **50 Marks** for I, II, and III Year students.
 - Continuous Internal Evaluation (CIE):
 - Average of two mid exams – 25 Marks
 - Project Work – 10 Marks
 - Assignments – 5 Marks
 - Seminar/Presentation – 5 Marks
 - Viva on Theory – 3 Marks
 - Clean & Green Activities and Attendance – 2 Marks
- 6. Paper Setters / Subject Experts** – Preparation and approval of panel for examinations and related Board of Studies deliberations.
- 7. Research and Extension Activities** – Encouraging student research projects, industry collaborations, internships, and community outreach initiatives in Data Science

8. **Skill Development and Employability Enhancement** – Introduction of certificate, add-on, and value-added courses in emerging domains.
9. **Feedback and Quality Assurance** – Mechanism for structured feedback collection from stakeholders (students, alumni, industry experts, and faculty) and its incorporation into curriculum and teaching practices for continuous improvement.
10. **Any Other Matter with the Permission of the Chair.**

RESOLUTIONS

1. Implementation of Pedagogical Practices

- The Board of Studies approved the syllabus, blueprint, and model question paper for all Data Science courses.
- It was resolved to integrate innovative teaching methods such as ICT-enabled learning, project-based learning, and blended learning into regular teaching practices.

2. Departmental Academic Activities (2025–26)

- The BoS resolved to organize:
 - One student workshops.
 - Student Development Programs (hackathons, coding challenges, and internships in Data Science-related fields).

3. Curriculum Revision and Updation

- It was resolved to revise and update the Data Science curriculum by incorporating emerging and industry-relevant courses such as Machine Learning, Data Analytics, Data Visualization etc. to enhance students' analytical and employability skills.

4. Adoption of APSICHE Model Curriculum

- It was resolved to implement the **APSICHE-prescribed model curriculum** for I Year students (2025–26 batch).

5. Assessment and Evaluation Methods

- The following assessment scheme was approved:
 - **Internal Assessment:** 50% weightage (I, II, and III Year students).
 - **End Semester Examination:** 50 Marks (I, II, and III Year students).
- **Continuous Internal Evaluation (CIE):**
 - Average of two mid exams – 25 Marks
 - Project Work – 10 Marks
 - Assignments – 5 Marks
 - Seminar/Presentation – 5 Marks

- Viva on Theory – 3 Marks
- Clean & Green Activities and Attendance – 2 Marks

6. Paper Setters / Subject Experts

- The BoS approved the proposed panel of **external examiners, question paper setters, and subject experts**

7. Research and Extension Activities

- It was resolved to encourage student research projects in Data Science, guided by faculty members.
- Students shall be encouraged to present research papers at conferences/seminars and publish in **UGC CARE/Scopus-indexed journals** focusing on Data Science and related domains.
- Collaborations with industries, research labs, and government agencies in the field of Data Science will be promoted.

8. Skill Development and Employability Enhancement

- The BoS approved the introduction of certificate courses in:
 - Indian Mathematics and Foundations of Machine Learning

9. Feedback and Quality Assurance

- A structured feedback mechanism will be implemented to collect inputs from students, alumni, industry experts, and faculty regarding the Data Science curriculum.
- The BoS resolved that feedback shall be analyzed every year and necessary corrective actions will be taken to enhance curriculum and teaching quality.

P. R. Government College (Autonomous), Kakinada
Department of Computer Science
Members Present – Board of Studies Meeting (2025–26)

Program: B.Sc. (Data Science)

Date: 12-08-2025 (Forenoon)

Mode: Online

The Board of Studies meeting for the **B.Sc. Data Science** program under the Department of Computer Science was held on **12th August 2025 (Forenoon)**. The meeting was chaired by **Mr. R. V. Satyanarayana**, Lecturer In-Charge, Department of Computer Science.

The following members attended the meeting and approved the resolutions adopted during the session:

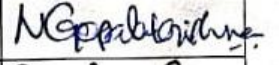
S. No	Name of the Person	Designation	Signature
1	Sri. R V Satyanarayana, Lecturer Incharge, Department of Computer Science	Chairman	 14/8/25
2	Sri. K Rasmi Ranjan, Lecturer in Computer Science, GDC(A), Tuni.	University Nominee	
3	Smt.N Naga Subrahmanyeswari, Lecturer in Computer Science, ASD College for Women (A), Kakinada	Subject Expert-1	N. N. S. Eswar
4	Sri. N. Gopala Krishna, Lecturer in Computer Science, GDC, Mondapeta.	Subject Expert-2	
5	Sri. P Swamy Vandanam, Managing Director, BDPS Computers, Kakinada	Representative from Industry	
6	Sri. A Anantha Teja, Lecturer in Computer Science	Member	
7	Ms. Peruri Susmitha, Lecturer in Computer Science	Member	
8	Sri. Chinta Moses Raju, Lecturer in Computer Science	Member	
9	Mrs. M Varalakshmi, Lecturer in Computer Science	Member	
10	MS. J Lakshmi Gayatri, Lecturer in Computer Science	Member	J. Lakshmi Gayatri
11	Sri. P A Sai Ganesh, Lecturer in Computer Science	Member	
12	Sri. Sakala Apparao, Consultant, Cap Gemini	Student Alumni Member	-
13	Devarakonda Bhuvaneshwari, II B.Sc. (DS)	Student Member	
14	Rongali Jagadeesh, II B.Sc. (DS)	Student Member	

PITHAPUR RAJAH'S GOVT DEGREE COLLEGE (AUTONOMOUS) KAKINADA

DEPARTMENT OF COMPUTER SCIENCE

UNDER CBCS PATTERN

Courses for the Academic Year 2025-26

COURSE STRUCTURE OF B.Sc. (Data Science)

S.No	Semester	Course Code	Title of the Course(Paper)	Marks in SEE	Marks in CIA	Hrs/Week			
						L	T	P	C
1	SEM-I	Major-1	Computer Fundamentals and Office Automation	50	50	3	-	-	3
2			Computer Fundamentals and Office Automation Lab	50	-	-	-	2	1
3		Major-2	Problem Solving Using C	50	50	3	-	-	3
4			Problem Solving Using C Lab	50	-	-	-	2	1
5		LSC I	AI Fundamentals	50	50	4	-	-	4
6			AI Fundamentals Lab	-	-	-	-	2	0
7	SEM-II	Major-3	Python Programming and Data Structures	50	50	3	-	-	3
8			Python Programming and Data Structures Lab	50	-	-	-	2	1
9		Major-4	Statistical Foundations for Data Science	50	50	3	-	-	3
10			Statistical Foundations for Data Science Lab	50	-	-	-	2	1
11		LSC 2	Applications Of Artificial Intelligence	50	50	3	-	-	3
12			Applications Of Artificial Intelligence	50	--	-	-	2	1
13	SEM-III	Major-5	Python programming for Data Analysis	50	50	3	-	-	3
14			Python programming for Data Analysis Lab	50	-	-	-	2	1
15		Major-6	Inferential and applied statistics	50	50	3	-	-	3
16			Inferential and applied statistics Lab	50	-	-	-	2	1
17		Major-7	Data mining techniques using R	50	50	3	--	--	3
18			Data mining techniques using R Lab	50	--	-	--	2	1
19		Major-8	Web technologies	50	50	3	--	--	3
20			Web technologies Lab	50	--	-	--	2	1

21	SEM-IV	Major-9	Data visualization using Tableau	50	50	3	--	-	3
22			Data visualization using Tableau Lab	50	--	-	-	2	1
23		Major-10	Data visualization using python	50	50	3	-	-	3
24			Data visualization using python Lab	50	--	-	--	2	1
25		Major-11	Introduction to SQL & Advanced Tableau	50	50	3	-	-	3
26			Introduction to SQL & Advanced Tableau Lab	50	--	-	-	2	1
27	INTERNSHIP			100	--	-	-	-	4
28	SEM-V	Major-12	Supervised Machine Learning with Python	50	50	3	-	-	3
29			Supervised Machine Learning with Python Lab	50	--	-	-	2	1
30		Major-13	Unsupervised Machine Learning with Python	50	50	3	-	-	3
31			Unsupervised Machine Learning with Python Lab	50	--	-	-	2	1
32	SEM-VI	Major-14A	Web Scraping with Python	50	50	3	-	-	3
33			Web Scraping with Python Lab	50	--	-	-	2	1
34		Major -14B	Predictive & Advanced Analytics using R	50	50	3	-	-	3
35			Predictive & Advanced Analytics using R Lab	50	--	-	-	2	1
36		Major-15A	Advanced Data Analysis Using Python	50	50	3	-	-	3
37			Advanced Data Analysis Using Python Lab	50	--	-	-	2	1
38		Major-15B	Data Wrangling with Java Script	50	50	3	-	-	3
39			Data Wrangling with Java Script Lab	50	--	-	-	2	1
	SEM-VI	APPRENTICESHIP		200	--	-	-	-	12

L=Lecture T=Tutorial P=Practical C=Credits

PANEL OF NAMES FOR APPOINTMENT OF EXAMINERS/PAPERSETTERS 2025-26

S.NO	NAME OF THE LECTURER	NAME OF THE COLLEGE
1	Dr. N Sridhar	Government Degree College for Men, Srikakulam
2	Smt. Naga Subramanyeswari	ASD Women's College ,Kakinada
3	Sri. D.Suneel	G.D.C.(A), Rajamahendravaram
4	Sri RASMI RANJAN KHANSAMA	GDC, TUNI
5	Dr. Ch. V. M. Hari	Dr VS Krishna G.D.C.(A), Visakhapatnam
6	Sri. D. V. Raghava Swamy	Dr VS Krishna G.D.C.(A), Visakhapatnam
7	Sri. BODALA RAVI KUMAR	GDC, Vizianagaram
8	Sri. R Ashok Kumar	SCIM Govt. College, Tanuku
9	Sri. SSVAS Samba Murthy	GDC, Paderu
10	Dr. Jahnvi	VS Krishna College, Visakhapatnam
11	Sri. E Jyothi Kiranmai	SCIM Govt. College, Tanuku
12	Sri. D Vijay Kumar	SCIM Govt. College, Tanuku
13	Smt. U Sandhya Rani	GDC(A), Rajahmundry
14	Sri H Devaraj	GDC(A), Rajahmundry
15	Sri P Narasinga Rao	GDC(A), Rajahmundry
16	Sri D Seeta Ramudu	GDC(A), Rajahmundry

PITHAPUR RAJAH'S GOVT DEGREE COLLEGE (AUTONOMOUS)::KAKINADA

DEPARTMENT OF COMPUTERSCIENCE

Marks Distribution for the I Year, II Year & III year

Internal: 50 marks

External: 50 marks

S.No.	Activities	Marks Allotted
1	Two Internal Mid Term Exams (Avg of two).. for 25marks	25 Marks
2	Project(10M), Viva voce(3M), Assignments(5M), seminars(5M),clean & green and attendance-(2M)	25 Marks
		Total - 50 Marks

B.Sc. (Hons.) Data Science

Program Specific Outcomes (PSOs)

After completion of the program, students will be able to:

1. **Perform Data Analysis & Interpretation:** Apply statistical methods, inferential reasoning, and advanced data analysis techniques using Python, R, and SQL to extract, interpret, and effectively communicate insights from both structured and unstructured datasets.
2. **Demonstrate Data Management & Engineering Skills:** Design and implement efficient data wrangling, integration, and visualization solutions using modern tools such as Tableau, Python, JavaScript, and SQL to support decision-making across diverse application domains.
3. **Develop Machine Learning & Predictive Models:** Build, train, and deploy supervised and unsupervised machine learning models using Python and R, and apply predictive and advanced analytics techniques to address real-world business and societal problems.
4. **Apply Applied Data Science & Professional Competencies:** Integrate knowledge gained through labs, internships, and apprenticeships to solve practical data science challenges, while upholding professional ethics, collaborating effectively in teams, and engaging in lifelong learning with emerging data technologies.

B.Sc (Honours) with Single Major																								
Semester	Major* (4 Cr)			Minor (4 Cr)			AECC (3 Cr)			Multi Disny' (2 Cr)			Skill Enhanceme nt Courses (2Cr)			OOTC			Env. Edn (2 Cr)			Total		
	C	H	Cr	C	H	Cr	C	H	Cr	C	H	Cr	C	H	Cr	C	H	Cr	C	H	Cr	C	H	Cr
Sem 1	2*	10	8				2	8	6	1	2	2	2	4	4							7	24	20
Sem 2	2	6+4	8	1	3+2	4	2	8	6				2	4	4							7	27	22
Community Service Project of 180 hours with 4 Credits.																								
Student is eligible for Exit Option-1 with the award of Certificate in respective discipline																								
Sem 3	4	12+8	16	1	3+2	4				1	2	2	1	2	2							7	29	24
Sem 4	3	9+6	12	2	6+4	8				1	2	2	1	2	2							7	29	24
Short-Term Internship/Apprenticeship/OJT of 180 hours with 4 Credits.																								
Student is eligible for Exit Option-2 with the award of Diploma in respective major with minor																								
Sem 5	4	12+8	16	2	6+4	8													1	2	2	7	32	26
Sem 6	Semester Internship/Apprenticeship/OJT with 12 Credits.																							
Student is eligible for Exit Option-3 with the award of Degree in respetive major																								
Sem 7	3	9+6	12										2*	6+4	8	1	2	2	1	2	0	6	29	22
Sem 8	3	9+6	12										2*	6+4	8	1	2	2	1	2	0	6	29	22
	21		84	6		24	4		12	3	6	6	10	32	28	2	4	4	2	4	0	47		160
20 Additional Credits for 10 month mandatory Internship/OJT/Apprenticeship																								
C Courses			H Hours			Cr Credits			OOTC Open Online Transdisciplinary															
IKS# Indian Knowledge Systems - Audit Course																								

SEMESTER-I

	Pithapur Rajah's Government College(A)::Kakinada Department of Computer Science	Program: I B.Sc. (DS) Semester: I
	Course Name: Computer Fundamentals and Office Automation	
Major-1	Hours Allocated: 3hrs/week	Credits: 3

Course Objectives:

- Understand the evolution of computer systems, various number systems, and the fundamental components of a computer.
- Explain the functional organization of computers, types of computer systems, and networking fundamentals including topologies and Internet basics.
- Gain proficiency in using word processing and presentation tools for creating professional documents and visual presentations.
- Develop skills in using spreadsheet software for performing calculations, data manipulation, and visualization.
- Apply advanced data analysis and visualization techniques using spreadsheets for effective decision-making and reporting.

Course Outcomes:

- Identify and convert between different number systems and describe the evolution and generations of computers.
- Illustrate the block diagram and explain the working of computer components, input/output devices, and memory hierarchy.
- Create and format professional documents and presentations using MS Word/Google Docs and PowerPoint/Google Slides.
- Perform data entry, use formulas and functions, generate charts, and apply conditional formatting in spreadsheets for analysis.
- Utilize advanced spreadsheet features such as Pivot Tables, Data Validation, and Dashboards for comprehensive data visualization and decision support.

UNIT-I

Number Systems, Evolution, Block Diagram and Generations.

Number Systems: Binary, Decimal, Octal, Hexadecimal; conversions between number systems.

Evolution of Computers: History from early mechanical devices to modern-day systems. Block Diagram of a Computer: Components like Input Unit, Output Unit, Memory, CPU (ALU + CU).
Generations of Computers: First to Fifth Generation – technologies, characteristics, examples.

UNIT-II

Basic organization and N/W fundamentals:

Computer Organization: Functional components – Input/Output devices, Storage types, Memory hierarchy.
Types of Computers: Micro, Mini, Mainframe, and Supercomputers.
Networking Fundamentals: Definition, need for networks, types (LAN, WAN, MAN), topology (Star, Ring, Bus).
Internet Basics: IP Address, Domain Name, Web Browser, Email, WWW.

UNIT-III

Word Processing and presentations:

Word Processing Basics: Using MS Word/Google Docs – formatting, styles, tables, mail merge.
Presentation Tools: Using PowerPoint/Google Slides – slide design, animations, transitions.
Applications: Creating resumes, reports, brochures, and presentations.
Keyboard Shortcuts.

UNIT-IV

Spreadsheet Basics:

Spreadsheet Concepts: Understanding rows, columns, cells in tools like MS Excel/Google Sheets, cell referencing.
Functions and Formulae: SUM, AVERAGE, IF, COUNT.
Charts and Graphs: Creating visual representations
Data Handling: Sorting, filtering, conditional formatting.
Text Functions: LEFT, RIGHT, MID, LEN, TRIM, CONCAT, TEXTJOIN
Advanced Functions: Logical: IF, AND, OR, IFERROR, Lookup: VLOOKUP, HLOOKUP, XLOOKUP, INDEX, MATCH

UNIT-V

Data Analysis and Visualization:

Conditional Formatting: Custom rules, Color scales, Icon sets, Data bars
Data Analysis Tools: Pivot Tables and Pivot Charts, Data Validation (Drop-downs, Input Messages, Error Alerts), What-If Analysis: Goal Seek, Scenario Manager, Data Tables
Charts and Dashboards: Creating Interactive Dashboards, Using slicers with Pivot Tables, Combo Charts and Sparklines
Productivity Tips: Using Named Ranges, Freeze Panes, Split View

Text Book(s)

- Fundamentals of Computers, Reema Thareja, Oxford University Press, Second Edition
- Fundamentals of Computers, V. Rajaraman – PHI Learning
- Introduction to Computers by Peter Norton – McGraw Hill
- Microsoft Office 365 In Practice by Randy Nordell – McGraw Hill Education

Reference Books:

- Excel 2021 Bible by Michael Alexander, Richard Kusleika – Wiley
- Networking All-in-One For Dummies by Doug Lowe – Wiley
- Microsoft Official Docs and Training: <https://learn.microsoft.com>
- Google Workspace Learning Center: <https://support.google.com/a/users>

Major-1	 Pithapur Rajah's Government College(A)::Kakinada Department of Computer Science	Program: I B.Sc. (DS) Semester: I
	Course Name: Computer Fundamentals and Office Automation	
	Hours Allocated: 3hrs/week	Credits: 3

MODEL BLUE PRINT

EXAM STRUCTURE:

Section	Questions Given	To Answer	Marks Each	Total
Section-I (Part-A and Part-B Essay Questions)	6	3	10	30
Section-II (Section-II Short Questions)	7	4	5	20

UNIT-WISE DISTRIBUTION:

UNIT	Essay Qs (10m)	Short Qs (5m)	Total Marks
I	1	2	20
II	2	1	25
III	1	1	15
IV	1	2	20
V	1	1	15

Total Questions: 6 (Essay) + 7 (Short) = 13

Questions to Answer: 3 (Essay) + 4 (Short) = 7

Total Marks before Choice: 95

Final Exam Marks: 50

Choice Percentage: 47.36% $[(95-50)/95 \times 100]$

	Pithapur Rajah's Government College(A)::Kakinada Department of Computer Science		Program: I B.Sc. (DS) Semester: I
	Course Name: Computer Fundamentals and Office Automation	Hours Allocated: 3hrs/week	
Major-1	MODEL PAPER		
TIME: 2hrs		Max.Marks:50M	

SECTION-I

Answer any THREE questions (Must attempt at least one from each Part). Each question carries 10 Marks.
3X10=30M

PART-A

1. Explain different number systems and their conversions with examples.
2. Explain the functional components of a computer and memory hierarchy.
3. Explain the features and uses of MS Word/Google Docs in word processing.

PART-B

4. Describe different types of computer networks and their topologies.
5. Explain spreadsheet basics, cell referencing, and commonly used functions in MS Excel/Google Sheets.
6. Explain conditional formatting and its types like color scales, icon sets, and data bars.

SECTION-II

Answer any FOUR questions. Each question carries 5 Marks.

5X4=20M

7. Draw and explain the block diagram of a computer system.
8. Write short notes on early mechanical computing devices.
9. Write short notes on types of computers.
10. Write short notes on mail merge and table creation in MS Word.
11. Write short notes on text functions like LEFT, RIGHT, MID, LEN, and CONCAT
12. Explain sorting, filtering, and conditional formatting in spreadsheets.
13. Write short notes on creating interactive dashboards and using slicers.

 Major-1	Pithapur Rajah's Government College(A)::Kakinada Department of Computer Science	Program: I B.Sc. (DS)
	Course Name: Computer Fundamentals and Office Automation Lab	Semester: I
	Hours Allocated: 2hrs/week	Credits: 1

List of Experiments

1. Demonstration of Assembling and Disassembling of Computer Systems.
2. Identify and prepare notes on the type of Network topology of your institution.
3. Prepare your resume in Word.
4. Using Word, write a letter to your higher official seeking 10-days leave.
5. Prepare a presentation that contains text, audio and video.
6. Using a spreadsheet, prepare your class Time Table.
7. Using a Spreadsheet, calculate the Gross and Net salary of employees (Min 5) considering all the allowances.
8. Generate the class-wise and subject-wise results for a class of 20 students. Also generate the highest and lowest marks in each subject.
9. Using IF, AND, OR, and IFERROR to Automate Grade Evaluation.
 - a. Create a table of student scores in different subjects.
 - b. Use IF to assign grades (A/B/C/Fail).
 - c. Use IFERROR to handle missing scores or invalid data.
10. Employee Database Search Using VLOOKUP, HLOOKUP, XLOOKUP, INDEX, and MATCH
 - a. Create a database of employees (Name, ID, Department, Salary).
 - b. Implement VLOOKUP to search by employee ID.
 - c. Use HLOOKUP to extract department heads by role.
 - d. Apply XLOOKUP for more flexible searches.
 - e. Use INDEX + MATCH as an alternative to VLOOKUP.
11. Sales Report Analysis Using Pivot Tables and Charts
 - a. Use a dataset of product sales (Product, Region, Date, Quantity, Revenue).
 - b. Create Pivot Tables to summarize data by region/product.
 - c. Insert Pivot Charts for visual analysis (e.g., bar, line).
 - d. Add slicers to make the dashboard interactive.
12. Designing a Data Entry Form with Drop-downs and Input Rules
 - a. Create a student registration form.
 - b. Add drop-down lists for course selection using Data Validation.

- c. Add input messages to guide users.
- d. Add error alerts for wrong entries.

13. Monthly Budget Planning using Goal Seek and Scenario Manager

- a. Create a simple personal budget (income, expenses, savings).
- b. Use Goal Seek to determine income needed to save a desired amount.
- c. Use Scenario Manager to compare different budgeting scenarios (best/ worst/ realistic case).
- d. Create a one-variable Data Table to analyze how different expenses affect savings.

14. Dashboard Creation Using Combo Charts, Sparklines & Slicers

- a. Use existing sales or attendance data.
- b. Insert combo charts (e.g., column + line).
- c. Add sparklines to show trends.
- d. Use slicers with Pivot Tables to control dashboard elements.
- e. Finalize and format for interactivity.

	Pithapur Rajah's Government College(A)::Kakinada Department of Computer Science	Program: I B.Sc. (DS) Semester: I
	Course Name: Problem Solving Using C	
Major-2	Hours Allocated: 3hrs/week	

Learning Objectives:

- Understand the fundamentals of computer programming, Apply structured problem- solving approaches using algorithms, flowcharts, and C programming constructs.
- Develop efficient logic using decision-making, loop, and jump control statements.
- Utilize derived data types like arrays and strings for modular program design.
- Design and implement modular solutions using functions, recursive logic, pointer operations, and dynamic memory management.
- Handle complex data structures including structures, unions, and text file operations.

Learning Outcomes:

On Completion of the course, students will be able to-

- Understand basic computing concepts, programming paradigms and write structured C programs.
- Apply control flow statements to solve logical and repetitive tasks in C.
- Implement arrays and string operations to manage and manipulate data efficiently.
- Design modular code using functions, recursion, and appropriate parameter passing.
- Utilize pointers and memory operations for effective data handling. Demonstrate competence in dynamic memory allocation and text file processing.

UNIT-I

Introduction to computer programming:

Introduction, Types of software, Compiler and interpreter, Concepts of Machine level, Assembly level and high-level programming, Flowcharts and Algorithms, Fundamentals of C: History of C, Features of C, C Tokens-variables and keywords and identifiers, constants and Data types, Rules for constructing variable names, Operators, Structure of C program, Input/output statements in C-Formatted and Unformatted I/O

UNIT-II

Control statements:

Decision making statements: if, if else, else if ladder, switch statements. Loop control statements: while loop, for loop and do-while loop. Jump Control statements: break, continue and goto.

UNIT-III

Derived data types in C:

Arrays: One Dimensional arrays - Declaration, Initialization and Memory representation; Two Dimensional arrays -Declaration, Initialization and Memory representation. Strings: Declaring & Initializing string variables; String handling functions, Character handling functions.

UNIT-IV

Functions:

Pointers: Pointer data type, Pointer declaration, initialization, accessing values using pointers. Pointer arithmetic, Pointers and arrays.

Function Prototype, definition and calling. Return statement. Nesting of functions. Categories of functions. Recursion (Basic Concept only). Parameter Passing by address & by value. Local and Global variables. Storage classes: automatic, external, static and register.

UNIT-V

Dynamic Memory Management:

Introduction, Functions-malloc, calloc, realloc, free Structures: Basics of structure, structure members, accessing structure members, nested structures, array of structures, structure and functions, structures and pointers. Unions - Union definition; difference between Structures and Unions. Working with text files - modes: opening, reading, writing and closing text files.

Text Books:

1. Programming in ANSI C, E. Balagurusamy, Tata McGraw Hill, 6 th Edn,
2. Computer fundamentals and programming in C, Reema Theraja, Oxford University Press

Reference Books:

1. Let us C, Y Kanetkar, BPB publications
2. Head First C: A Brain-Friendly Guide, David Griffiths, Dawn Griffiths

	Pithapur Rajah's Government College(A)::Kakinada Department of Computer Science	Program: I B.Sc. (DS) Semester: I
	Course Name: Problem Solving Using C	
Major-2	Hours Allocated: 3hrs/week	

MODEL BLUE PRINT

EXAM STRUCTURE:

Section	Questions Given	To Answer	Marks Each	Total
Section-I (Part-A and Part-B Essay Questions)	6	3	10	30
Section-II (Section-II Short Questions)	7	4	5	20

UNIT-WISE DISTRIBUTION:

UNIT	Essay Qs (10m)	Short Qs (5m)	Total Marks
I	2	1	25
II	1	2	20
III	1	2	20
IV	1	1	15
V	1	1	15

Total Questions: 6 (Essay) + 7 (Short) = 13 Questions to

Answer: 3 (Essay) + 4 (Short) = 7

Total Marks before Choice: 95

Final Exam Marks: 50

Choice Percentage: 47.36% $[(95-50)/95 \times 100]$

	Pithapur Rajah's Government College(A)::Kakinada Department of Computer Science		Program: I B.Sc. (DS) Semester: I
	Course Name: Problem Solving Using C	Hours Allocated: 3hrs/week	
Major-2	MODEL PAPER		
TIME:2hrs		Max.Marks:50M	

Section -I

Answer any three of the following questions. Must attempt at least one question from each part. Each question carries 10 Marks.

3X10=30M

Part – A

1. What is a flowchart? Explain different symbols used in flowcharts.
2. What is an Operator? Explain different types of Operators in detail?
3. What are control statements? Explain different looping statements in C with syntax and examples

Part – B

4. What is a String? Describe the various string handling functions in C
5. What is Pointer Data Type? Explain in detail?
6. What are structures? Explain structure declaration, initialization, and accessing members with suitable examples

Section II

Answer any four of the following questions. Each question carries 5 marks. 4 X 5 = 20M

7. What is typecasting? Explain with example?
8. Explain the basic structure of C program
9. Demonstrate switch statement in C
10. Write a C program to find a given number is prime or not
11. Develop a C program to find largest number in an array of numbers
12. What is recursion? Write a recursive program to find factorial of a number
13. Compare and contrast structure and union.

	Pithapur Rajah's Government College(A)::Kakinada Department of Computer Science	Program: I B.Sc. (DS) Semester: I
	Course Name: Problem Solving Using C lab	
Major-2	Hours Allocated: 2hrs/week	Credits: 1

List of Experiments:

1. Write a program to check whether the given number is Armstrong or not.
2. Write a program to find the sum of individual digits of a positive integer.
3. Write a program to generate the first n terms of the Fibonacci sequence.
4. Write a program to find both the largest and smallest number in a list of integer values
5. Write a program to demonstrate change in parameter values while swapping two integer variables using Call by Value & Call by Address
6. Write a program to perform various string operations.
7. Write a program to search an element in a given list of values.
8. Write a program that uses functions to add two matrices.
9. Write a program to calculate factorial of given integer value using recursive functions
10. Write a program for multiplication of two N X N matrices.
11. Write a program to sort a given list of integers in ascending order.
12. Write a program to calculate the salaries of all employees using the Employee (ID, Name, Designation, Basic Pay, DA, HRA, Gross Salary, Deduction, Net Salary) structure.
 - a. DA is 30 % of Basic Pay
 - b. HRA is 15% of Basic Pay
 - c. Deduction is 10% of (Basic Pay + DA)
 - d. Gross Salary = Basic Pay + DA+ HRA
 - e. Net Salary = Gross Salary - Deduction
13. Write a program to read / write the data from / to a file.
14. Write a program to reverse the contents of a file and store in another file.
15. Write a program to create Book (ISBN, Title, Author, Price, Pages, Publisher) structure and store book details in a file and perform the following operations
 - a. Add book details
 - b. Search a book details for a given ISBN and display book details, if available
 - c. Update a book details using ISBN
 - d. Delete book details for a given ISBN and display list of remaining Books

	Pithapur Rajah's Government College(A) Kakinada Department of Computer Science	Program: I B.Sc. Semester: I
LSC-1	Course Name: AI Fundamentals	
	Hours Allocated: 4hrs/week	Credits: 4

Course Objectives:

- Understand the fundamental concepts, history, and subfields of Artificial Intelligence and its real-world applications.
- Explore the various domains where AI is applied such as healthcare, finance, agriculture, and education.
- Analyze ethical considerations, bias, fairness, transparency, and accountability in AI systems.
- Familiarize with generative AI tools, prompt engineering concepts, and their importance in human–AI interaction.
- Apply prompt engineering techniques in different areas such as education, business, and creative content generation using AI tools.

Course Outcomes (Learning Outcomes):

- Explain the fundamentals, history, and various subfields of Artificial Intelligence.
- Identify and describe major real-world applications of AI across multiple industries.
- Evaluate ethical, fair, and transparent AI practices ensuring accountability and security in AI systems.
- Demonstrate an understanding of generative AI tools and prompt engineering concepts in AI/ML applications.
- Implement prompt engineering strategies for solving real-world problems in education, business, and creative industries.

Unit I. AI and its Subfields

Introduction to Artificial Intelligence, History, Definition, Artificial General Intelligence, Industry Applications of AI, Challenges in AI.

Knowledge Engineering, Machine Learning, Computer Vision, Natural Language Processing, Robotics.

Unit 2. Applications of AI

Healthcare, Finance, Retail, Agriculture, Education, Transportation.

Unit 3. Bias and Fairness in AI Systems

Ethics in AI, Bias and Fairness in AI Systems, Transparency in AI Systems, Accountability,

Security, Privacy, Inclusivity, Sustainability, Robustness, Reliability.

Unit 4. AI in Research, Generative AI and prompt engineering

AI in Experimentation and Multi-disciplinary research, Generative AI introduction, ChatGPT, Hugging Face, Gemini and other tools basics, Perplexity, Prompt engineering Definition and its importance, Role of Prompt Engineering in AI/ML Interaction, Emerging trends and Future Directions in AI.

Unit 5. Applications of Prompt engineering

Applications of Prompt Engineering: Education, Business & Commerce, Content Creation: AI for Creative Writing, AI for creative design, writing AI scripts for video, generating slides and slidesGPT usage, Designing thumbnails and channel branding with AI

TEXT BOOKS:

1. AI for Everyone: A Beginner's Handbook for Artificial Intelligence (AI) by Saptarsi Goswami, Amit Kumar Das , Amlan Chakrabarti
2. Prompt Engineering for Beginners: by Kapila Arora, Geetu Garg, Gaurav Arora.

REFERENCE BOOKS:

1. Let's Learn Artificial Intelligence: Base Module, Niti Ayog, Atal Innovation Mission.
2. Prompt Engineering for Generative AI: Future-proof inputs for Reliable AI-outputs by James Phoenix & Mike Taylor.
3. Generative AI Tutorial:https://www.w3schools.com/gen_ai/
4. Generative AI 360°: Practical Guide to ChatGPT, Midjourney & AI Tools to Boost Productivity & Creativity , For Professionals, Marketers & Entrepreneurs by Hitesh Motwani , ZebraLearn, 2025.
5. Generative AI: Prompt Engineering Basics:
6. Learn Generative AI Prompt Engineering for everyone. <https://www.coursera.org/learn/generative-ai-prompt-engineering-for-everyone?action=enroll>
7. Free Artificial Intelligence (AI) Tutorial - Hands-On Prompt Engineering for AI Beginners & Business User | Udemy, <https://www.udemy.com/course/prompt-engineering-for-ai-beginners-business-users>

LSC-1	 Pithapur Rajah's Government College(A) Kakinada Department of Computer Science	Program: I B.Sc. Semester: I
	Course Name: AI Fundamentals Hours Allocated: 4hrs/week	

MODEL BLUE PRINT

EXAM STRUCTURE:

Section	Questions Given	To Answer	Marks Each	Total
Section-I (Part-A and Part-B Essay Questions)	6	3	10	30
Section-II (Section-II Short Questions)	7	4	5	20

UNIT-WISE DISTRIBUTION:

UNIT	Essay Qs (10m)	Short Qs (5m)	Total Marks
I	1	2	20
II	1	1	15
III	1	1	15
IV	2	1	25
V	1	2	20

Total Questions: 6 (Essay) + 7 (Short) = 13

Questions to Answer: 3 (Essay) + 4 (Short) = 7

Total Marks before Choice: 95

Final Exam Marks: 50

Choice Percentage: 47.36% $[(95-50)/95 \times 100]$

	Pithapur Rajah's Government College(A) Kakinada Department of Computer Science	Program: I B.Sc. Semester: I
	Course Name: AI Fundamentals Hours Allocated: 4hrs/week	
Model Paper		
Time: 2Hrs		Max. Marks:50M

SECTION-I

Answer any THREE questions (Must attempt at least one from each Part). Each question carries 10 Marks.

PART-A

1. Describe the challenges faced in Artificial Intelligence and its major industry applications.
2. Describe the role of AI in education and transportation with suitable examples.
3. Discuss transparency, accountability, and privacy issues in Artificial Intelligence.

PART-B

4. Define Prompt Engineering and explain its importance in AI-ML interaction.
5. Discuss Generative AI and describe the features of tools like ChatGPT, Hugging Face, Gemini, and Perplexity.
6. Explain the applications of Prompt Engineering in education and business sectors.

SECTION-II

Answer any FOUR questions. Each question carries 5 Marks.

7. What is Artificial General Intelligence (AGI)?
8. Write any two applications of AI in real-world industries.
9. Write a short note on AI in education.
10. What is meant by bias in AI systems?
11. Write a short note on Prompt Engineering.
12. What is the use of Prompt Engineering in education?
13. How is AI used for creative writing?

	Pithapur Rajah's Government College(A) Kakinada Department of Computer Science	Program: I B.Sc. Semester: I
LSC-1	Course Name: AI Fundamentals-Practice Session	
	Hours Allocated: 2hrs/week	Credits: 0

Lab List

1. Create a mind map of AI subfields: NLP, CV, ML, Robotics, Knowledge Engineering using Canva/Napkin AI/ Similar Open AI tool
2. Text Analysis with Open-Source NLP Tools: **Tool:** Voyant Tools (text analysis web app)
 - Input sample texts (e.g., news articles, speeches).
 - Explore word frequency, keywords, sentiment.
 - Understand how NLP extracts meaning from text.
3. Train a basic image classifier using webcam images. Observe how the model "learns." Using Google Teachable Machine
 - Train two image categories (e.g., "Smiling" vs. "Not Smiling") using their own webcam images.
 - Observe how the model learns to classify.
 - Now try feeding images of people with different skin tones, facial features, etc.
 - Observe misclassifications or differences in confidence.
4. Simulate an AI chatbot helping a farmer or a student. You may use any GenAI tool of your choice. You may use the prompt below and also try your own.

Prompt:

"Act as an agriculture assistant. A farmer wants to know the best crop based on soil and season. Ask questions and suggest crops."

5. Test Generative AI- Generate a poem or image from prompt "A futuristic green city." using ChatGPT, Hugging Face (e.g., image or text generation)
6. Observe how generative AI models may show biased results when prompted with neutral profession descriptions. (Bing Image Creator / DALL·E on ChatGPT/ChatGPT). Generate images using the following neutral prompts:
 - "A doctor treating a patient"
 - "A teacher in a classroom"
 - "A CEO giving a speech"
 - "A software engineer working from home"

Observe and discuss:

- What gender/race/age are most commonly shown?

- Are the results stereotypical or diverse?
7. Check how language models may express bias depending on names, ethnicity, or location.

Use ChatGPT or Gemini

Prompts:

Prompt A:

“A person named Raj is applying for a bank loan. Will he be approved?”

Prompt B:

“A person named John is applying for a bank loan. Will he be approved?”

Change names, genders, and nationalities.

Observe the following and report your findings:

- Are the responses different?
 - Is one version more positive or negative?
 - Does the model express bias or hesitate?
 - Should AI make such predictions?
 - How do developers prevent this?
8. Exploring Text Generation and Summarization with Google AI Studio

Generate Creative Content

“Write a short story (150 words) about a robot who wants to become a chef.”

- Submit and read the AI-generated story.
- Discuss how detailed and creative the output is.

Summarize a Paragraph

Prompt:

Summarize the following paragraph in 3 sentences:

“Artificial Intelligence is a branch of computer science that aims to create intelligent machines that can mimic human thinking. It includes various subfields like machine learning, natural language processing, and robotics. AI is widely used in industries such as healthcare, finance, and transportation to improve efficiency and decision-making.”

- Submit and review the summary.
- Evaluate how well AI extracts key points.

Refine Your Prompt

Try changing the summary prompt to:

“Summarize the paragraph above in simple language for 10-year-olds.”

- Compare this output to the previous one.
- Note how prompt wording changes results.

9. AI for Creative Writing

Prompt:

“Write a short motivational story for 10-year-old students in under 150 words.”

10. Generate **Slides:** Tool: SlidesGPT/Other Free AI tool

Prompt:

“Create a 5-slide presentation on ‘AI in Smart Farming’.”

11. YouTube Thumbnails / Branding: Tool: Canva + Magic Media AI

Design a thumbnail using Canva’s AI tools with a prompt like:

“Design a YouTube thumbnail for a video titled ‘Top 5 AI Tools for Students’.”

SEMESTER-II

	Pithapur Rajahs Government College(A) Kakinada Department of Computer Science	Program: I B.Sc. (DS) Semester: II
	Course Name: Python Programming and Data Structures	
Major-3	Hours Allocated: 3hrs/week	Credits: 3

Course Objectives

1. To introduce the fundamentals of Python programming, including environment setup, syntax, and core concepts.
2. To develop problem-solving skills using control flow, functions, and modules.
3. To provide knowledge of Python data structures, file handling, and exception handling for effective programming.
4. To impart object-oriented programming concepts and GUI development skills for building applications.

Course Outcomes (COs)

After successful completion of the course, students will be able to:

1. Explain the basic features, syntax, data types, and operators of Python programming.
2. Apply control flow constructs, functions, and modules to develop structured Python programs.
3. Demonstrate the use of sequences, sets, and dictionaries for effective data handling and manipulation.
4. Implement file handling techniques and apply exception handling mechanisms for robust applications.
5. Develop object-oriented and GUI-based applications using Python.

Unit 1: Basics of Python Programming

Introduction to Python, Features of Python, Programming Modes - Interactive Mode & Script Mode, Identifiers, Naming Conventions, Keywords (Reserved Words), Built-in Data Types, Literals - Integer, Float, Complex, Boolean, String, Variables, Operators, Expressions, Assignment Statements, Input/Output Statements, Python Syntax (Lines, Comments, Indentation), Operators & Operands, Classification of Operators - Arithmetic Operators, Relational Operators, Logical Operators, Bitwise Operators, Assignment, Augmented Assignment, Identity Operators, Expressions & Precedence Rules

Unit 2: Control Flow, Functions & Modules

Control Flow - if Statement, if-else, if-elif-else. Iterative Statements – while, for, Nested Loops, Loop Control Statements – break, continue, pass, else with loops

Functions: Need for Functions, Defining & Invoking User-defined Functions, Return Statement, Function Input/ Output Cases, Scope of Variables - Local, Global, Nested Functions, Function Arguments - Required, Positional, Default, Variable-length, main() Function, Documentation Strings, Recursive Functions, Anonymous Functions (Lambda), Library Functions
Modules - Import, from..import, Creating & Using Modules, Namespaces

Unit 3: Core Data Types and Python Collections

Strings: Representation, Indexing, Slicing, Immutability, Operators, Methods, Formatting

Lists: Creation, Indexing, Slicing, Mutability, Common Methods, List Comprehension

Tuples: Immutability, Operations, Tuple Assignment

Sets and Frozensets: Methods, Mathematical Operations, Comprehension

Dictionaries: Key-Value Structure, Methods, Traversal, Nested Dictionaries

Unit 4: File Handling, Exception Management & Object-Oriented Programming

File Handling: Types, Opening, Reading, Writing, Closing, CSV Files, OS/ Pathlib Error Types, Exception Handling: try-except, raise, User-defined Exceptions, Assertions

OOP Concepts: Classes, Objects, Attributes, Methods, Constructor and Destructors **Encapsulation:** Private and Public Members

Inheritance: Single, Multilevel, Multiple, Method Overriding

Unit 5: Abstract Data Structures and GUI Programming

Abstract Data Structures (ADTs): Concepts and Importance.

Linked Lists: Definition, Types-Singly, Doubly, Circular; Node Structure, Insertion, Deletion, Traversal (Single Linked list implementation only).

Stacks: LIFO Principle, Implementation using List, Applications.

Queues: FIFO Principle, Implementation using List, Priority Queues

GUI Programming with Tkinter: Widgets (Label, Button, Entry, Menu, Listbox, Canvas etc.), Event Handling, Building Simple GUI Apps.

Textbooks:

1. Python Programming-An Object Oriented approach, Anita Goel, Universities Press
2. Python Programming using Problem Solving Approach Reema Thareja Oxford University Press 2020
3. Exploring Python, Budd T A, McGraw-Hill Education, 1st Edition, 2011.

Reference Book:

1. Python: The Complete Reference, Martin C. Brown, Mc Graw-Hill, 2018
2. Fundamentals of Python, Kenneth A. Lambert. (2019), First Programs,2nd Edition, CENGAGE Publication.

Major-3	 Pithapur Rajahs Government College(A) Kakinada Department of Computer Science	Program: I B.Sc. (DS) Semester: II
	Course Name: Python Programming and Data Structures Hours Allocated: 3hrs/week	

MODEL BLUE PRINT

EXAM STRUCTURE:

Section	Questions Given	To Answer	Marks Each	Total
Section-I (Part-A and Part-B Essay Questions)	6	3	10	30
Section-II (Short Answer Questions)	7	4	5	20

UNIT-WISE DISTRIBUTION:

UNIT	Essay Qs (10m)	Short Qs (5m)	Total Marks
I	2	1	25
II	1	2	20
III	1	2	20
IV	1	1	15
V	1	1	15

Total Questions: 6 (Essay) + 7 (Short) = 13

Questions to Answer: 3 (Essay) + 4 (Short) = 7

Total Marks before Choice: 95

Final Exam Marks: 50

Choice Percentage: 47.36% $[(95-50)/95 \times 100]$

 Pithapur Rajahs Government College(A) Kakinada Department of Computer Science	Program: I B.Sc. (DS) Semester : II	
	Course Name: Python Programming and Data Structures	
	Major-3	
Model Paper		
Time: 2hrs		Max. Marks: 50

SECTION-I

Answer any THREE questions (Must attempt at least one from each Part). Each question carries 10 Marks. 3X10=30M

PART-A

1. Explain the important features of Python and discuss why Python is considered a powerful and easy-to-learn programming language.
2. Describe Python's built-in data types with examples.
3. Explain the different types of loop/ iterative control flow statements in Python.

PART-B

4. Discuss various Python collections — List, Tuple, Set, and Dictionary — highlighting their characteristics, operations, and applications.
5. Explain file handling in Python. Write a Python program to open a text file, read its contents, and display the number of lines, words, and characters.
6. Explain the concept of Stack in Python. Discuss its implementation using list with examples.

SECTION-II

Answer any FOUR questions. Each question carries 5 Marks.

7. What are identifiers and keywords in Python? State the naming conventions with examples.
8. Write a Python function to find the factorial of a number using recursion.
9. Differentiate between local and global variables with examples.
10. Explain string slicing in Python and demonstrate any three string methods with examples.
11. What is a tuple? Explain tuple operations and the concept of immutability with an example.
12. Explain exception handling using `try`, `except`, and `finally` blocks with an example.
13. What is event handling in Tkinter? Write a simple GUI program that displays a message when a button is clicked.

	Pithapur Rajahs Government College(A) Kakinada Department of Computer Science	Program: I B.Sc. (DS) Semester : II
Major-3	Course Name: Python Programming and Data Structures	
	Hours Allocated: 2hrs/week	Credits: 1

1. Basic Python Programs:

- a. Write a program to display basic details (name, roll number, department) using print() and demonstrate different literal types (int, float, string, boolean, complex).
- b. Write a program to perform arithmetic, relational, logical, bitwise, and assignment operations on given inputs.

2. Control Flow Practice

- c. Write a program to find the largest of three numbers using if-elif-else.
- d. Write a program to check whether a number is prime or not using loops.
- e. Write a program to illustrate the use of loop control statements (break, continue, pass).

3. Functions and Recursion

- f. Write a program to define a function to calculate factorial of a number (using recursion).
- g. Write a program to demonstrate different types of function arguments (default, positional, keyword, variable-length).

4. Write a program to illustrate string slicing, concatenation, repetition, and built-in methods.
5. Write a program to create a list of numbers, perform insertion, deletion, searching, sorting, and list comprehension.
6. Write a program to demonstrate tuple packing, unpacking, and immutability.
7. Write a program to implement set operations (union, intersection, difference, subset, superset).
8. Write a program to create a dictionary of student roll numbers and marks, and perform add, update, delete, and traversal operations.
9. Write a program to read and display count of vowels, consonants, digits, and spaces of a text file.
10. Write a program to copy the contents of one file into another file.
11. Write a program to read and process student marks from a CSV file (calculate average, highest, lowest).

12. Write a program to demonstrate exception handling using try-except-finally.
13. Write a program to create a class Student with attributes and methods to display details.
14. Write a program to demonstrate single and multilevel inheritance.
15. Implement stack (LIFO) and queue (FIFO) using lists.
16. Implement singly linked lists: node creation, insertion, deletion, traversal.
17. Write a Tkinter program with Label, Entry, and Button widgets to take user input and display it.
18. Write a Tkinter program to create a simple calculator application



**Pithapur Rajah's Government College(A) Kakinada Department of
Computer Science**

Program: I B.Sc.
(DS)
Semester: II

Major-4

Course Name: Statistical Foundations for Data Science

Hours Allocated: 3hrs/week

Credits: 3

Course Objectives:

- To introduce the fundamental concepts of probability, uncertainty, and statistical reasoning.
- To develop the ability to describe, analyze, and interpret data using measures of central tendency and dispersion.
- To explain the concepts of random variables, probability distributions, and their applications in real-world problems.
- To familiarize students with correlation and regression techniques for understanding relationships between variables.
- To equip students with the skills to perform statistical inference, estimation, and hypothesis testing for decision-making.

Course Outcomes (Learning Outcomes):

- Understand and apply the basic principles of probability and statistical measures to real-life data.
- Compute and interpret measures of central tendency, dispersion, and data visualizations.
- Analyze discrete and continuous probability distributions and determine expectations and variances.
- Apply correlation and regression techniques to examine and model relationships between variables.
- Conduct hypothesis tests and construct confidence intervals to draw valid statistical conclusions.

Unit I: Fundamentals of Probability & Basic Statistics

Probability: Concept of Uncertainty, Axioms and rules of probability, Conditional probability and independence, Law of total probability and Bayes' theorem.

Measures of central tendency: Mean, Median, Mode

Measures of dispersion: range, interquartile range, variance, standard deviation Introduction to correlation and covariance

Data representation: histograms, bar charts, scatter plots

Unit II: Random Variables, Expectation, and Variance

Random variables: definition, types (discrete & continuous), and properties, Probability mass function (PMF) and probability density function (PDF), Cumulative distribution function (CDF), Mathematical expectation (mean), variance, and standard deviation, Moments and moment-generating functions.

Unit III: Probability Distributions

Discrete distributions: Binomial, Poisson, Geometric, Negative Binomial distributions - definitions, properties, and

examples.

Continuous distributions: Uniform, Normal (Gaussian), Exponential, Gamma distributions - definitions, properties, and applications Joint, marginal, and conditional distributions, Introduction to Central Limit Theorem.

Unit IV: Correlation and Regression

Bivariate data and scatter plots

Correlation: Pearson and Spearman coefficients, interpretation

Simple linear regression: model, estimation, properties, and analysis of variance, Multiple linear regression basics (conceptual understanding) Residuals and goodness of fit.

Unit V: Statistical Inference, Estimation, and Hypothesis Testing

Population and sample, parameters and statistics, Sampling distributions, Point and interval

estimation (confidence intervals), Tests of significance: z-test, t-test, chi-square test, and F-test, p-values and errors (Type I & II), Power of a statistical test

TEXT BOOKS:

1. Probability and Statistics for Engineers and Scientists, Ronald E. Walpole, Wiley
2. Sheldon M. Ross, Introduction to Probability and Statistics for Engineers and Scientists
3. Douglas C. Montgomery & George C. Runger, Applied Statistics and Probability for Engineers

REFERENCE BOOKS:

1. D.C. Agarwal, Statistics for Data Science and AI
2. Larry J. Stephens, Excel Data Analysis: Your visual blueprint for analyzing data, statistics, and AI.

	Pithapur Rajah's Government College(A) Kakinada Department of Computer Science	Program: I B.Sc. (DS) Semester: II
Major-4	Course Name: Statistical Foundations for Data Science	Credits: 3
	Hours Allocated: 3hrs/week	

EXAM STRUCTURE:

Section	Questions Given	To Answer	Marks Each	Total
Section-I (Part-A and Part-B Essay Questions)	6	3	10	30
Section-II (Section-II Short Questions)	7	4	5	20

UNIT-WISE DISTRIBUTION:

UNIT	Essay Qs (10m)	Short Qs (5m)	Total Marks
I	1	2	20
II	1	2	20
III	2	1	25
IV	1	1	15
V	1	1	15

Total Questions: 6 (Essay) + 7 (Short) = 13

Questions to Answer: 3 (Essay) + 4 (Short) = 7

Total Marks before Choice: 95

Final Exam Marks: 50

Choice Percentage: 47.36% $[(95-50)/95 \times 100]$

	Pithapur Rajah's Government College(A) Kakinada Department of Computer Science	Program: I B.Sc. (DS) Semester: II
	Course Name: Statistical Foundations for Data Science Hours Allocated: 3hrs/week	
Major-4		
Model Paper		

SECTION-I

Answer any **THREE** questions (Must attempt at least one from each Part). Each question carries 10 Marks.

PART-A

1. Describe the law of total probability and Bayes' theorem. Illustrate their applications.
2. Explain probability mass function (PMF), probability density function (PDF), and cumulative distribution function (CDF).
3. Explain the Binomial and Poisson distributions. Describe their definitions and properties.

PART-B

4. Explain the Normal and Exponential distributions. Discuss their characteristics, parameters, and uses.
5. Describe the concept of simple linear regression and its least squares estimation.
6. Explain the steps involved in hypothesis testing and discuss Type I & Type II errors.

SECTION-II

Answer any **FOUR** questions. Each question carries 5 Marks.

7. What is a histogram?
8. Write differences between mean and median.
9. What is a discrete random variable?
10. Write the properties of a CDF.
11. What is the Central Limit Theorem?
12. What is regression analysis?
13. What is the difference between a parameter and a statistic?

	<p align="center">Pithapur Rajah's Government College(A) ::Kakinada Department of Computer Science</p>	<p align="center">Program: I B.Sc. (DS) Semester: II</p>
<p align="center">Major-4</p>	<p align="center">Course Name: Statistical Foundations for Data Science Hours Allocated: 2hrs/week</p>	

Credits: 1

Lab List

Advanced Spreadsheets/Excel Lab/PSPP Open Source

1. Construct a contingency table from sales data and compute conditional probabilities. Verify independence of variables.
2. Apply Bayes' theorem on medical test data to compute the probability of disease given a positive result.
3. Calculate measures of central tendency (mean, median, mode) for student marks dataset.
4. Compute measures of dispersion (range, variance, standard deviation, IQR) for the same dataset and interpret variability.
5. Create a histogram of student marks and comment on the shape of the distribution.
6. Prepare bar charts of categorical data (e.g., Gender vs Section) and interpret group comparisons.
7. Generate scatter plots between Hours Studied and Exam Score, compute correlation and covariance, and interpret the relationship.
8. Random Variable Simulation: Simulate and visualize discrete/continuous random variables using Excel functions and Data Analysis Tool pack.
9. Expectation & Variance Calculation: Use Excel formulas to compute expected value, variance, and standard deviation from given datasets.
10. Modeling Discrete Probability Distributions: Generate and plot Binomial and Poisson distributions; analyze probabilities and mean/variance.
11. Modeling Continuous Distributions: Simulate Normal and Exponential distributions; use NORM.DIST, NORM.INV, EXPON.DIST functions.
12. Correlation Analysis: Calculate Pearson/Spearman correlation coefficients; visualize with scatter plots and trendlines.
13. Linear Regression in Excel: Fit a linear regression model, interpret coefficients, predict new values; use REGRESSION tool.
14. Statistical Inference & Estimation: Create confidence intervals using Excel formulas; visualize sampling distributions
15. Hypothesis Testing: Perform z-test, t-test, chi-square tests in Excel; interpret p-values and results.

	Pithapur Rajah's Government College(A) Kakinada Department of Computer Science	Program: I BSc(AI/IOT/DS)
	Applications Of Artificial Intelligence	Semester: II
LSC2	Hours Allocated: 3hrs/week	Credits: 3

Course Objectives

- Provide a foundation in the AI ecosystem, including hardware, cloud, and edge platforms relevant to Computer science.
- Familiarize students with different types of datasets and public repositories used in AI research.
- Develop skills in building AI data pipelines through collection, annotation, cleaning, and preprocessing.
- Expose students to no-code AI platforms, vite coding, and workflow automation tools for rapid AI application development.
- Introduce applications of AI in networking, cybersecurity, and digital forensics, highlighting both opportunities and challenges.

Course Outcomes

On successful completion of this course, students will be able to:

- Explain the role of AI hardware, edge devices, and cloud platforms in enabling applications in Computer Science.
- Differentiate data types and utilize public datasets relevant to AI.
- Design and implement a conceptual AI data pipeline for solving problems.
- Apply no-code/low-code AI platforms, vite coding tools, and workflow automation for simple AI-powered applications.
- Evaluate the role of AI in networking, cybersecurity, and digital forensics, and discuss its challenges and future scope.

Unit 1

Infrastructure and Platforms for Building Applications using AI

Hardware used in building AI applications: Processors - CPU, GPU, TPU, NPU, Memory - RAM, VRAM, Storage - HDD, SSD

Platforms for building applications using AI: Online platforms (Example - Google AutoML,

H2O.ai, Teachable Machine or similar platforms - for practice only); Desktop (No-code/Low-code) platforms (Orange Data Mining, KNIME, Weka, RapidMiner or similar tools - for practice only).

Edge AI: Concept; Applications in daily life in devices like Refrigerators, Led Bulbs, Surveillance Cameras, Micro Ovens, Smart Cars/Scooters; Edge AI in smart Appliances

Unit 2

Foundations of Data - Types, Ethics and Utility in Building Applications using AI Importance of data in building AI applications: Data as the fuel for AI, Role of big data in training AI models.

Conceptual Foundations of Data: Data vs. Information vs. Knowledge.

Structure of Data: Structured, Semi-Structured, and Unstructured Data.

Modalities of Data: Text, Image, Audio, Video, Tabular, Time-Series, and Spatial Data.

Formats of Data: Text Formats (CSV, JSON, XML), Image Formats (JPEG, GIF, PNG), Audio/Video (MP3, WAV, MP4, AVI).

Data Repositories: Definition of public Datasets; Definition of private Datasets; Importance of Public Datasets, Popular Public Dataset Repositories (Example - Kaggle, Hugging Face Datasets, UCI Machine Learning Repository, Google Dataset Search or similar ones - for demonstration only), Dataset licensing and usage rights.

Ethics, Privacy in Data Usage: Privacy concerns related to data usage; Regulations governing data usage - GDPR, HIPAA (Overview), Ethical use of data, Responsible AI data practices.

Unit - 3

The AI Data Pipeline: From Collection to Model Readiness

The AI Data Pipeline: Stages and Components: Key Stages (Data Collection, Annotation, Preprocessing, Splitting, Feeding into AI Models)

Core Components: Ingestion, Storage, Processing, Validation, Delivery

Data Collection Methods for AI: Manual Input (Surveys, forms, human-curated entries), Sensors & IoT Devices (Real-time data from physical environments), System Logs & Transactions, Web Scraping (Automated extraction from websites), APIs (Structured data access from external platforms)

Data Annotation and Labelling: Definition & Importance; Annotation Methods: Manual Annotation, Automated Annotation; Types of Annotation: Classification, Bounding Boxes, Segmentation, Transcription, Named Entity Recognition (NER)

Data Cleaning and Preprocessing: Importance of data cleaning; Understanding “Dirty” Data:

Missing Values, Duplicates, Incorrect Formats, Outliers, Noise; Steps in Data Cleaning: Identify Issues, Handle Errors (Imputation, Removal), Validate Cleaned Data

Data Splitting: Splitting data into training set and test set.

Data Transformation Techniques: Normalization, Transformation, Feature Engineering (Conceptual)

Unit 4

AI-Powered No-Code Development: Vibe Coding and Workflow Automation

Vibe Coding: Concept & Workflow: What is Vibe Coding and how it works; Comparison: Vibe Coding vs. traditional programming; Tools Overview: Google AI Studio, Firebase Studio, Replit, Cursor, Windsurf (for demonstration and practice only); Tool Selection: Choosing the right platform for your needs; Benefits & Challenges: Advantages and limitations of Vibe Coding; Paradigm Shift: From code-centric to prompt-driven development; Prompt Crafting: Structure and examples of effective app prompts.

Workflow Automation using AI: Fundamentals: What is workflow automation and its relevance in the AI era; Real-world Applications: Auto-email responses, Feedback summarization, Social media alerts & analytics; Toolset Overview: Zapier, Power Automate, n8n, Lindy and other similar tools (for demonstration and practice only); Choosing the Right Tool: Features, use cases, and integration potential.

Unit-

5 AI in Networks, Cybersecurity, and Forensics

AI in Networking: Need of AI in Network Management, How AI works in Traffic Prediction & Intrusion Detection, Uses of AI in Optimization, Fault Management, and Routing

AI in Cyber Security: Need of AI in Cyber Security, How AI works in Cyber Security, Uses of AI in Cyber Security, Challenges and Considerations of AI in Cyber Security

AI in Digital Forensics: How AI enhance digital forensic investigations, Role of AI in cyber-forensic evidence acquisition and analysis, Overcoming challenges and limitations of AI in forensics, The future outlook for AI-powered forensic tools

	Pithapur Rajah's Government College(A)::Kakinada Department of Computer Science	Program: I B.Sc. (AI/IOT/DS)
	Applications Of Artificial Intelligence Hours Allocated: 3hrs/week	Semester: II Credits: 3

MODEL BLUE PRINT

EXAM STRUCTURE:

Section	Questions Given	To Answer	Marks Each	Total
Section-I (Part-A and Part-B Essay Questions)	6	3	10	30
Section-II (Section-II Short Questions)	7	4	5	20

UNIT-WISE DISTRIBUTION:

UNIT	Essay Qs (10m)	Short Qs (5m)	Total Marks
I	2	1	25
II	1	2	20
III	1	2	20
IV	1	1	15
V	1	1	15

Total Questions: 6 (Essay) + 7 (Short) = 13 Questions to

Answer: 3 (Essay) + 4 (Short) = 7

Total Marks before Choice: 95

Final Exam Marks: 50

Choice Percentage: 47.36% $[(95-50)/95 \times 100]$

	<p align="center">Pithapur Rajah's Government College(A) Kakinada Department of Computer Science</p>	<p align="center">Program: I BSc (AI/IOT/DS) Semester: II</p>
<p align="center">LSC2</p>	<p align="center">Applications Of Artificial Intelligence Lab</p> <p align="center">Hours Allocated: 2hrs/week</p>	

Suggested Lab Practicals (No Coding)

Lab 1 - Exploring Public Datasets (Orange Data Mining)

- Visit a public repository (Kaggle, UCI, data.gov.in)
- Download a dataset (e.g., rainfall data, literacy rates, or traffic accident statistics)
- Procedure:
 1. Open Orange → Add *File* widget → Load a CSV (e.g., Titanic dataset).
 2. Connect to *Data Table* → View rows/columns.
 3. Connect to *Data Info* → Check attributes, data types.
 4. View in *Data Table* and *Distributions* widget.
- **Observation:** Note numeric, categorical, missing values.
- **Outcome:** Students understand structured data format in CSV.

Lab 2 – Exploring Cybersecurity Datasets (Orange Data Mining)

- Dataset: Kaggle Cybersecurity dataset.
https://www.kaggle.com/datasets/teaminciribo/cyber-security-attacks?select=cybersecurity_attacks.csv
- Procedure:
 1. Load dataset into Orange (File widget).
 2. View using **Data Table** and **Distributions** widgets.
 3. Identify numerical (packet size, duration) and categorical (protocol type, attack type) attributes.
- **Observation:** Note features that indicate “attack” vs. “normal traffic.”
- **Outcome:** Students understand the type of features used in intrusion detection.

Lab 3 - Understanding Dataset Metadata and Formats

- Take two datasets in different formats (CSV, JSON)
- View metadata (description, features, size, license)
- Compare domain-specific datasets (e.g., medical vs. finance)

Lab 4 - Data Annotation Exercise

- Use **MakeSense.ai** or **VGG Image Annotator (VIA)**
- Annotate 10 sample images (traffic signs, fruits, or medical scans)
- Export annotations in XML or YOLO format
- Discuss annotation errors and challenges

Lab 5 - Data Cleaning and Visualization (Orange Data Mining)

- **Aim:** To clean dirty data and visualize categorical and numeric attributes.
- Procedure:
 1. Load dataset.
 2. Connect *File* → *Edit Domain* (to change types) and *Impute* (to fill missing values).
 3. Compare cleaned vs. original in *Data Table*.
 4. *Distributions* widget.
 5. Check various features distribution.

(Optional: Create simple bar charts/line charts to visualize trends using Google Looker Studio)

- **Observation:** Missing values filled with mean/median., Graphical representation of data.
- **Outcome:** Learn importance of data cleaning., Students learn importance of visualization in preprocessing.

Lab 6: Train/Test Split in Orange

- **Aim:** To split dataset for AI training/testing.
- Procedure:
 1. Load Titanic dataset.
 2. Connect *File* → *Data Sampler* (70% train, 30% test).
 3. Connect outputs to *Data Table* widgets to view.
- **Observation:** Students see two different subsets.
- **Outcome:** Concept of model validation using split data.

Lab 7 – Writing a Detailed Prompt for a Simple Game App (Generative AI)

- **Objective:** Understand prompt engineering by designing a game idea.
- Activity:

1. Open ChatGPT (or Gemini, Copilot).
2. Write a detailed prompt like *“Create a simple text-based treasure hunt game with levels, scoring, and random challenges.”*
3. Ask the AI to refine game rules, scoring, and characters.
4. Document how prompt detail changes the AI’s response.

- **Outcome:** Students learn how detailed prompts shape AI outputs.

Lab 8 – Create a Portfolio Website using Vibe Coding Tool

- **Objective:** Learn how AI-assisted coding tools can automatically generate websites from simple instructions.

- Activity:

1. Open **Vibe Coding Tool** (Windsurf/Cursor/Firebase Studio/Any other vibe coding tool).

2. Give a natural language instruction:

“Create a personal portfolio website for a Computer Science student. It should have sections: About Me, Education, Skills, Projects, and Contact.”

3. Experiment with different prompts to change **layout, theme, or color scheme** (e.g., *“Make it a modern dark theme with blue highlights.”*).

4. Preview the generated site and customize content.

- **Outcome:** Students experience how **AI converts prompts into functional websites** with minimal coding effort.

Lab 9 – Develop an Interactive Education Quiz App using Vibe Coding Tool

- **Objective:** Understand AI’s role in creating **educational applications**.

- Activity:

1. Open **Vibe Coding Tool**.

2. Give _____ prompt:

“Build an interactive quiz app for students with multiple-choice questions on AI basics. Include features: Start Quiz, Show Score, Retry.”

3. Refine the app by asking AI to:

- Add **timer** for each question.
- Show **correct/incorrect answers** instantly.
- Add a **Leaderboard** page.

4. Test the app by playing the quiz.

- **Outcome:** Students see how **AI-generated apps** can support **e-learning and assessments**.

Lab 10-Automating Feedback Summarization using n8n and AI

Objective: Automatically summarize student feedback responses using AI and email the summary to the teacher.

Steps:

1. **Trigger Node:** Google Sheets (watch new row for feedback).
2. **AI Node:** Send text to OpenAI/Gemini API for summarization.
(Get a free API from **OpenRouter** (<https://openrouter.ai/>) → Gives free trial credits + access to multiple models.)
3. **Action Node:** Gmail → email summarized feedback to teacher.
4. **Test:** Enter sample feedback in Google Sheet → receive AI summary via email.
5. **Discussion:** How AI reduced manual effort in reading every response.

Outcome: Students see how automation + AI can transform data into insights instantly.

Lab 11 – Using AI Functions in Google Sheets

Objective: Enable students to experience Google Sheets' built-in AI-powered features like summarizing, categorizing, sentiment analysis, and text generation through simple prompts within the spreadsheet environment.

Tools & Setup

Enable Google Sheets with Workspace Labs

<https://workspace.google.com/labs-sign-up/u/1/>

Follow the References and experiment with summarizing, categorizing, sentiment analysis, and text generation using =AI() function

https://support.google.com/docs/answer/15820999?visit_id=638919819014625788-1742465261&p=ai-function&rd=1 <https://support.google.com/docs/answer/13447609?hl=en&sjid=9077695331310534831-NC>
https://support.google.com/docs/answer/13635180?hl=en&ref_topic=13450085&sjid=9077695331310534831-NC

Outcome: Students will experience various AI functions within a spreadsheet-text generation, summarization, categorization, sentiment analysis.

Lab 12- Deep Fake Image Detection Objective

Enable students to critically assess image authenticity using multiple free AI tools, understanding the strengths and limitations of each.

Tools:

Deepfake-O-Meter: https://zinc.cse.buffalo.edu/ubmdfl/deep-o-meter/landing_page

Decopy AI Image Detector: <https://decopy.ai/ai-image-detector/>

Procedure

1. Collect Images

- 2 real images (e.g., faces from Unsplash or personal photos)
- 2 AI-generated or manipulated images (e.g., from Midjourney, DALL·E, or Google AI studio)

2. Run through DeepFake-o-Meter

- Visit the platform and upload an image.
- Note the output: what algorithms flag or overall score for authenticity.

3. Use Decopy AI Image Detector

- Upload the same images.
- Check results indicating whether the image appears AI-generated.

Observation: How AI tools help in Digital Forensics.

Note: *The Tools suggested above are tentative. Teacher/Student is free to choose any other similar tool to execute the said lab experiments.*

Books/References

1. **Data Science for Beginners**, Andrew Park
(Introductory concepts of data types, collection, cleaning, and visualization without coding)
2. **AI Basics for Non-Programmers**, Tom Taulli
(Clear explanations of AI data lifecycle and real-world use cases)
3. **Data Preparation for Machine Learning**, Jason Brownlee
(Conceptual understanding of dataset quality, preprocessing, and pipelines)
4. **Hands-On Data Science for Non-Programmers**, David Meerman Scott
(Spreadsheet-based data exploration and visualization)
5. You Look Like a Thing and I Love You – Janelle Shane
6. Vibe coding: <https://cloud.google.com/discover/what-is-vibe-coding>
<https://www.ibm.com/think/topics/vibe-coding>
<https://firebase.google.com/docs/studio/prompting>
7. Workflow Automation: <https://www.ibm.com/think/topics/workflow-automation>
<https://www.ibm.com/think/topics/ai-workflow>
<https://n8n.io/>
8. AI in Cyber Security: <https://www.geeksforgeeks.org/ethical-hacking/ai-in-cybersecurity/>
9. AI in Networks:
<https://www.cisco.com/site/us/en/learn/topics/artificial-intelligence/what-is-ai-in-networking.html>
10. AI in Digital Forensics:
<https://www.eccouncil.org/cybersecurity-exchange/cyber-talks/ai-and-ml-in-digital-forensics-the-future-of-forensic-investigations/>

	Pithapur Rajah's Government College(A) Kakinada Department of Computer Science	Program: I BSc(AI/IOT/DS)
	Applications Of Artificial Intelligence	Semester: II
LSC2	MODEL QUESTION PAPER	
Time: 2Hrs		Max. Marks: 50M

SECTION-1

Answer any three of the following questions. Must attempt at least one question from each part. Each question carries 10 Marks. 3X10=30M

PART-A

1. Explain the different types of processors (CPU, GPU, TPU, NPU) used in AI applications and discuss how each contributes to AI performance.
2. What is Edge AI? Describe its architecture and explain how it enables real-time intelligence in smart devices.
3. Explain the importance of data as the “fuel for AI.” How does big data contribute to the effectiveness of AI systems?

PART-B

4. Explain the key stages and components of an AI Data Pipeline.
5. Explain the concept of **Vibe Coding**. How is it different from traditional programming?
6. Explain how AI enhances cybersecurity through intrusion detection and threat prediction.

SECTION-II

Answer any four of the following questions. Each question carries 5 marks. 4 X 5 = 20M

7. Define NPU and state its importance in AI hardware acceleration.
8. Differentiate between Data, Information, and Knowledge
9. List various modalities of data used in AI applications.
10. Explain the key stages and components of an AI Data Pipeline.
11. Define “Data Ingestion” and its role in the data pipeline.
12. Explain prompt-driven development?
13. Write the Uses of AI in network management.

SEMESTER-III



Pithapur Rajahs Government College(A) Kakinada
Department of Computer Science

Program: II B.Sc.

Course 5	Course Name: Python Programming For Data Analysis	(Data Science) Semester : III
	Hours Allocated: 3hrs/week	Credits: 3

Aim and objectives of Course:

- To be able to Program in Python
- To know and understand the data Analysis phases
- To know the usage of all libraries

Learning outcomes of Course:

- Understands and learn all basic concepts of
- Python Program Data Analysis methods in Python
- Get used with Python Programming environments

UNIT I:

What is Data Analysis? Differences between Data Analysis and Analytics, What is Python, Why Python for Data Analysis? What is Library, Essential Python Libraries. I Python and Jupyter Notebook. Python Language Basics: Variables, Identifiers, Comments, Data types, type conversion, operators, operations on strings, control statements (selection and iteration).

UNIT II:

Built-in Data Structures, Functions, Files and Operating System. NumPy Basics: Arrays and Vectorized Computation, The Numpy ndarray, Universal Functions, Array-Oriented Programming with Arrays, File Input and Output with Arrays, Linear Algebra, Pseudorandom Number Generation.

UNIT III:

Getting Started with Pandas: Introduction to Pandas Data Structures, Essential Functionality, Summarizing and Computing Descriptive Statistics Data Loading, Storage and File Formats: Reading and Writing Data in Text Format, Binary Data Formats, Interacting with Web APIs, Interacting with Databases.

UNIT IV:

Data Cleaning and Preparation: Handling Missing Data, Data Transformation, String Manipulation. **Data Wrangling:** Join, Combine and Reshape: Hierarchical Indexing, Combining and Merging Datasets, Reshaping and Pivoting.

UNIT V:

Introduction to Modeling Libraries in Python: Interfacing between pandas and Model code,

Creating model descriptions with Patsy, Introduction to stats models. Plotting and Visualization: A brief matplotlib API Primer, Plotting with Pandas and Seaborn, Other Python visualization tools.

TEXT BOOKS:

1. Wes McKinney “Python for Data Analysis” O’reilly Publications Second edition
2. Charles R Suverance “Python for Everybody” Exploring data using Python 3

REFERENCE BOOKS:

1. John Zelle Michael Smith Python Programming, second edition 2010

Co-curricular Activities:

Take up any application which involves the python coding. Example Case studies/Simulators: (<https://knightlab.northwestern.edu/2014/06/05/five-mini-programming-projects-for-thepython-beginner/>)

- Dice Rolling Simulator
- Guess the number
- Text based adventure game
- Hangman

Continuous assessment:

Let the students be tested in the following questions from each unit

1. What is data analysis. List out the differences between data analysis and data analytics
2. What is Python? Explain Python basics
3. Explain NumPy Basics
4. What is Data Loading. Explain Pandas Data Structures
5. What is Data Cleaning. Explain different phases in it
6. Explain Plotting and Visualization in Python

	Pithapur Rajahs Government College(A) Kakinada Department of Computer Science	Program: II B.Sc. (Data Science) Semester : III
	Course Name: Python Programming For Data Analysis Hours Allocated: 3hrs/week	

MODEL BLUE PRINT

EXAM STRUCTURE:

Section	Questions Given	To Answer	Marks Each	Total
Section-I (Part-A and Part-B Essay Questions)	6	3	10	30
Section-II (Section-II Short Questions)	7	4	5	20

UNIT-WISE DISTRIBUTION:

UNIT	Essay Qs (10m)	Short Qs (5m)	Total Marks
I	1	2	20
II	2	1	25
III	1	2	20
IV	1	1	15
V	1	1	15

Total Questions: 6 (Essay) + 7 (Short) = 13

Questions to Answer: 3 (Essay) + 4 (Short) = 7

Total Marks before Choice: 95

Final Exam Marks: 50

Choice Percentage: 47.36% $[(95-50)/95 \times 100]$

 Course 5	Pithapur Rajahs Government College(A) Kakinada Department of Computer Science		Program: II B.Sc. (Data Science) Semester :III
	Course Name: Python Programming For Data Analysis		
	Hours Allocated: 3hrs/week		Credits: 3
	Model Paper		
	Time: 2hrs		Max. Marks: 50

SECTION-I

Answer any THREE questions (Must attempt at least one from each Part). Each question carries 10 Marks.

PART-A

14. Explain the differences between *Data Analysis* and *Data Analytics* with suitable examples.
15. Explain the different built-in data structures in Python (lists, tuples, sets, dictionaries) with suitable examples.
16. Explain the data structures in Pandas: *Series* and *DataFrame* with examples.

PART-B

17. Explain in detail the methods for handling missing data in Pandas.
18. Compare different Python visualization libraries: Matplotlib, Pandas plotting, and Seaborn.
19. What is NumPy ndarray? Explain its creation, properties, and operations with examples.

SECTION-II

Answer any FOUR questions. Each question carries 5 Marks.

20. Illustrate the different built-in data types in Python with suitable examples.
21. What are universal functions (ufuncs) in NumPy? Give examples.
22. What is the use of describe() function in Pandas?
23. Write short notes on data transformation using *map* and *apply* functions.
24. What is statsmodels? Mention any two features.
25. Describe Python conditional statements briefly.
26. Mention file handling functions in Python and their purpose.

	Pithapur Rajahs Government College(A)::Kakinada Department of Computer Science	Program: II B.Sc. Data Science Semester : III
	Course Name: Python Programming For Data Analysis Lab Hours Allocated: 3hrs/week	

1. Use Matplotlib to create and display an inline plot in a Jupyter Notebook
2. Implement commands of Python Language basics
3. Create Tuples, Lists and illustrate slicing conventions.
4. Demonstrate built-in sequence functions.
5. Clean the elements and transform them by using List, Set and Dict Comprehensions.
6. Create a functional pattern to modify the strings in a high level.
7. Write a Python Program to cast a string to a floating-point number but fails with Value Error on improper inputs using Errors and Exception handling.
8. Create an n array object and use operations on it.
9. Use arithmetic operations on Numpy Arrays
10. Using Numpy array perform Indexing and Slicing Boolean Indexing, Fancy Indexing operations
11. Create an image plot from a two-dimensional array of function values.
12. Implement some basic array statistical methods (sum, mean, std, var, min,max, argmin, argmax, cumsum and cumprod) and sorting with sort method.
13. Implement numpy.random functions.
14. Plot the first 100 values on the values obtained from random walks.
15. Create a data frame using pandas and retrieve the rows and columns in it by performing some indexing options and transpose it.
16. Implement the methods of descriptive and summary statistics
17. Load and write the data from and to different file formats including WebAPIs.
18. Implement the data Cleaning and Filtering methods(Use NA handling methods, fillna function arguments)
19. Transform the data using function or mapping
20. Rearrange the data using un-stack method of hierarchical Indexing
21. Implement the methods that summarize the statistics by levels.
22. Use different Join types with how argument and merge data with keys and multiple keys.

	Pithapur Rajahs Government College(A) Kakinada Department of Computer Science	Program: II B.Sc. (Data Science) Semester: III
	Course Name: INFERENTIAL AND APPLIED STATISTICS	
	Hours Allocated: 3hrs/week	Credits: 3

Course Objectives:

- Understand key statistical concepts and distributions, including sampling, convergence, and classical theorems.
- Learn estimation techniques and hypothesis testing for Binomial, Poisson, and Normal distributions.
- Apply parametric and non-parametric tests for data analysis and interpretation.
- Analyze and model time series data using trend estimation methods.
- Understand and compute vital statistics, including mortality, fertility rates, and life tables.

Course Outcomes:

By the end of this course, students will be able to:

- knowledge about important inferential aspects such as point estimation, test of hypotheses and associated concepts, knowledge about inferences from Binomial, Poisson and Normal distributions as illustrations, concept about non-parametric method and some important non-parametric tests.
- Time series data, its applications to various fields and components of time series, Various data collection methods enabling to have a better insight in policy making, planning and systematic implementation, Construction and implementation of life tables, Population growth curves, population estimates and projections.
- Real data implementation of various demographic concepts as outlined above through practical assignments.

UNIT - I

Concepts: Population, Sample, Parameter, statistic, Sampling distribution, Standard error. convergence in probability and convergence in distribution, law of large numbers, central limit theorem (statements only). Student's t- distribution, F – Distribution, χ^2 -Distribution: Definitions, properties and their applications.

UNIT - II

Theory of estimation and Hypothesis: Estimation of a parameter, criteria of a good estimator – unbiasedness, consistency, efficiency, & sufficiency and. Binomial, Poisson & Normal Population parameters estimate by MLE method. Confidence Intervals. Concepts of statistical hypotheses, null and alternative hypothesis, critical region, two types of errors, level of significance and power of a test. Examples in case of Binomial, Poisson and Normal distributions.

UNIT - III

Sample tests: t-test for single mean, difference of means and paired intervals for mean(s). standard deviation(s) and correlation coefficient(s). Test for goodness of fit and independence of attributes. F-test for equality of variances. Non-parametric tests- their advantages and disadvantages, comparison with parametric tests. Measurement scale- nominal, ordinal, interval and ratio.

UNIT - IV

Time Series: Time Series and its components with illustrations, additive, multiplicative models. Trends: Estimation of trend by free hand curve method, method of semi averages. Determination of trend by least squares (Linear trend, parabolic trend only), moving averages method.

UNIT - V

Vital Statistics: Introduction, definition and uses of vital statistics, sources of vital statistics. measures of different Mortality and Fertility rates, Measurement of population growth. Life tables: construction and uses of life tables.

TEXT BOOKS:

1. BA/BSc II year statistics - statistical methods and inference - Telugu Academy by A.Mohanrao, N.Srinivasa Rao, Dr R.Sudhakar Reddy, Dr T.C. RavichandraKumar.
2. K.V.S. Sarma: Statistics Made Simple: Do it yourself on PC.PHI.
3. Fundamentals of applied statistics : VK Kapoor and SCGupta.
4. BA/BSc III year paper - III Statistics - applied statistics - Telugu academy by prof.K.SrinivasaRao, Dr D.Giri. Dr A.Anand, Dr V.PapaiahSastry.

REFERENCE BOOKS:

1. Brockwell, P.J. and Devis, R.A. (2003). Introduction to Time Series Analysis. Springer.
2. Chatfield, C. (2001). Time Series Forecasting., Chapman & Hall.

3. Srinivasan, K. (1998). Demographic Techniques and Applications. Sage Publications
4. Srivastava O.S. (1983). A Text Book of Demography. Vikas Publishing House
5. Fundamentals of Mathematics statistics : VK Kapoor and SCGuptha.
6. Outlines of statistics, Vol II : Goon Guptha, M.K.Guptha, Das GupthaB.
7. Introduction to Mathematical Statistics : HoelP.G.
8. Hogg Tanis Rao: Probability and Statistical Inference. 7th edition.Pearson.

Student Activity

Create a custom Super Store dataset (or use a modified version of the default Tableau Superstore dataset), then design and build an interactive dashboard that addresses key statistical and visualization concepts.

General Requirements

1. Dashboard size must be exactly 1250px wide by 750px tall.
2. Use exactly 5 containers in the dashboard layout.
3. Include a dedicated filter pane within one of the containers.
4. Use at least three filters with consistent padding.
5. Ensure clean and organized layout using vertical or horizontal containers.
6. Include meaningful titles, tooltips, and legends where necessary.
7. Use a dataset with time, category, and geographic fields.
8. All visualizations must be interactive and filterable.

Continuous assessment:

Let the students be tested in the following questions from each unit

1. Join tables using Tableau and explain generated fields (e.g., date parts, hierarchies).
2. Create and interpret various charts like bar, line, pie, scatter, maps, and text tables.
3. Demonstrate understanding of aggregation, calculated fields, and table calculations.
4. Use standard map view to plot custom locations with geographical data.
5. Develop an ad-hoc analysis dashboard with interactive filters and parameters.

	Pithapur Rajahs Government College(A) Kakinada Department of Computer Science	Program: II B.Sc. (Data Science) Semester: III
	Course Name: INFERENTIAL AND APPLIED STATISTICS Hours Allocated: 3hrs/week	

MODEL BLUE PRINT

EXAM STRUCTURE:

Section	Questions Given	To Answer	Marks Each	Total
Section-I (Part-A and Part-B Essay Questions)	6	3	10	30
Section-II (Section-II Short Questions)	7	4	5	20

UNIT-WISE DISTRIBUTION:

UNIT	Essay Qs (10m)	Short Qs (5m)	Total Marks
I	1	2	20
II	1	2	20
III	2	1	25
IV	1	1	15
V	1	1	15

Total Questions: 6 (Essay) + 7 (Short) = 13

Questions to Answer: 3 (Essay) + 4 (Short) = 7

Total Marks before Choice: 95

Final Exam Marks: 50

Choice Percentage: 47.36% $[(95-50)/95 \times 100]$

	Pithapur Rajahs Government College(A) Kakinada Department of Computer Science		Program: II B.Sc. (Data Science) Semester: III
	Course 6	Course Name: INFERENTIAL AND APPLIED STATISTICS	
	Hours Allocated: 3hrs/week		Credits: 3
Model Paper			
Max. Time: 2 Hrs			Max. Marks: 50

SECTION-I

Answer any THREE questions (Must attempt at least one from each Part). Each question carries 10 Marks. 3X10=30

PART-A

1. Define chi-square distribution and explain its applications.
2. Explain about criteria of a good estimator.
3. Explain test for goodness of fit.

PART-B

4. Explain difference between parametric tests and non parametric tests.
5. Explain about components of time series.
6. Explain measures of fertility.

SECTION-II

Answer any FOUR questions. Each question carries 5 Marks. 4X5=20

7. Define sample and sampling distribution.
8. Explain convergence probability.
9. Define null and alternative hypothesis.
10. Explain about level of significance?
11. Explain nominal and ordinal scale.
12. Explain about additive and multiplicative model?
13. Write about uses of vital statistics.

	Pithapur Rajahs Government College(A) Kakinada Department of Computer Science	Program: II B.Sc. (Data Science) Semester: III
	Course Name: Inferential And Applied Statistics Lab	
Course 6	Hours Allocated: 3hrs/week	Credits: 1

Lab List

1. Large sample test for difference of means.
2. Large sample test for single proportion
3. Large sample test for difference of proportions , standard deviations , correlation coefficient.
4. Small sample test for single mean, difference of means and correlation coefficient
5. Paired t-test(paired samples).
6. Small sample test for single variance(χ^2 - test)

Time Series:

7. Measurement of trend by method of moving averages(odd and even period)
8. Measurement of trend by method of Least squares(linear and parabola)
9. Determination of seasonal indices by method simple averages
10. Determination of seasonal indices by method of Ratio to moving averages

Vital Statistics:

11. Computation of various Mortality rates
12. Computation of various Fertility rates
13. Computation of various Reproduction rates.
14. Construction of Life Tables

	Pithapur Rajahs Government College(A) Kakinada Department of Computer Science	Program: II B.Sc. (Data Science) Semester : III
	Course Name: DATA MINING TECHNIQUES USING R	
Course 7	Hours Allocated: 3hrs/week	

Course Objectives:

- Introduce fundamental concepts of data warehousing and data mining.
- Explore the stages and techniques in the data mining process.
- Familiarize with data mining query languages and system integration.
- Teach data pre-processing techniques for improving data quality.
- Understand data generalization and concept description methods.

Course Outcomes:

- Define and differentiate key concepts of data mining and KDD.
- Apply data mining techniques for effective knowledge extraction.
- Utilize data mining query languages to interact with databases.
- Implement data pre-processing steps like cleaning and transformation.
- Understand and apply concept description and attribute-oriented induction.

UNIT I:

An idea on Data Warehouse, Data mining-KDD versus data mining, Stages of the Data Mining Process-Task primitives., Data Mining Techniques – Data mining knowledge representation.

UNIT II

Data mining query languages- Integration of Data Mining System with a Data Warehouse-Issues, Data pre-processing – Data Cleaning, Data transformation – Feature selection – Dimensionality reduction

UNIT III

Concept Description: Characterization and comparison What is Concept Description, Data Generalization by Attribute-Oriented Induction(AOI), AOI for Data Characterization, Efficient Implementation of AOI.

Mining Frequent Patterns, Associations and Correlations: Basic Concepts, Frequent Itemset Mining Methods: Apriori method, generating Association Rules, Improving the Efficiency of Apriori, Pattern-Growth Approach for mining Frequent Item sets.

UNIT-IV

Classification Basic Concepts: Basic Concepts, Decision Tree Induction: Decision Tree Induction Algorithm, Attribute Selection Measures, Tree Pruning. Bayes Classification Methods.

UNIT-V

Association rule mining: Antecedent, consequent, multi-relational association rules, ECLAT. Case study on Market Basket Analysis.

Cluster Analysis: Cluster Analysis, Partitioning Methods, Hierarchical methods, Density based methods-DBSCAN.

TEXT BOOKS:

1. Jiawei Han, Micheline Kamber, Jian Pei. "Data Mining: Concepts and Techniques", 3rd Edition, Morgan Kaufmann Publishers, 2011.
2. Adelchi Azzalini, Bruno Scapa, "Data Analysis and Data mining", 2nd Edition, Oxford University Press Inc., 2012.
3. Data Mining, The Textbook (2015) by Charu Aggarwal.

REFERENCES BOOKS:

1. Alex Berson and Stephen J. Smith, "Data Warehousing, Data Mining & OLAP", 10th Edition, Tata McGraw Hill Edition, 2007.
2. G.K. Gupta, "Introduction to Data Mining with Case Studies", 1st Edition, Eastern Economy Edition, PHI, 2006.

Student Activities:

1. Students should be able to implement Data Mining algorithms provided the relevant data
2. Given the data, students can visualize all statistical measures
3. Differentiate the types of mining problems and identify what type of algorithms are to be implemented.

Continuous assessment:

Let the students be tested in the following questions from each unit

1. What is Data Mining and KDD? Where Data Mining fits in KDD Process
2. Describe all Preprocessing methods
3. Explain Data Description and AOI Algorithm
4. Explain Classification and Write any Decision tree induction algorithm
5. Explain the concept of clustering and write any algorithm to form clusters.

	Pithapur Rajahs Government College(A) Kakinada Department of Computer Science	Program: II B.Sc. (Data Science) Semester: III
	Course Name: DATA MINING TECHNIQUES USING R	
Course 7	Hours Allocated: 3hrs/week	Credits: 3

MODEL BLUE PRINT

EXAM STRUCTURE:

Section	Questions Given	To Answer	Marks Each	Total
Section-I (Part-A and Part-B Essay Questions)	6	3	10	30
Section-II (Section-II Short Questions)	7	4	5	20

UNIT-WISE DISTRIBUTION:

UNIT	Essay Qs (10m)	Short Qs (5m)	Total Marks
I	1	2	20
II	1	1	15
III	2	1	25
IV	1	1	15
V	1	2	20

Total Questions: 6 (Essay) + 7 (Short) = 13

Questions to Answer: 3 (Essay) + 4 (Short) = 7

Total Marks before Choice: 95

Final Exam Marks: 50

Choice Percentage: 47.36% $[(95-50)/95 \times 100]$

	Pithapur Rajahs Government College(A) Kakinada Department of Computer Science	Program: IIB.Sc. (Data Science) Semester :III
Course 7	Course Name: DATA MINING TECHNIQUES USING R	Credits: 3
	Hours Allocated: 3hrs/week	
Model Paper		

SECTION-I

Answer any THREE questions (Must attempt at least one from each Part). Each question carries 10 Marks.

PART-A

1. Explain the differences between Knowledge Discovery in Databases (KDD) and Data Mining. Discuss their relationship.
2. Explain the role and features of data mining query languages with examples.
3. What is Concept Description? Explain characterization and comparison with examples.

PART-B

4. Explain the Apriori algorithm with an example and discuss how to generate association rules.
5. Explain the basic concepts of classification in data mining.
6. Describe the case study of Market Basket Analysis and its implications for business decision-making.

SECTION-II

Answer any FOUR questions. Each question carries 5 Marks.

7. Define Data Mining.
8. Mention any two task primitives in data mining.
9. Define feature selection.
10. What is Attribute-Oriented Induction?
11. Name any two attribute selection measures.
12. Define antecedent and consequent in association rule mining.
13. What is the main idea of DBSCAN?

	Pithapur Rajahs Government College(A)::Kakinada Department of Computer Science	Program: II B.Sc. Data Science Semester: III
	Course Name: DATA MINING TECHNIQUES USING R Lab	
Course 7	Hours Allocated: 2hrs/week	Credits: 1

Lab Programs List

1. Get and Clean data using dplyr exercises.
2. Visualize all Statistical measures (Mean, Mode, Median, Range, Inter Quartile Range etc., using Histograms, Boxplots and Scatter Plots).
3. Create a data frame with atleast 10 entries of columns EMPID, EMPNAME, SALARY, STARTDATE
 - a) Extract two column names using column name.
 - b) Extract the first two rows and then all columns.
 - c) Extract 3rd and 5th row with 2nd and 4th column.
4. Create a data frame with 10 observations and 3 variables and add new rows and columns to it using 'rbind' and 'cbind' function.
5. Create a function to discretize a numeric variable into 3 quantiles and label them as low, medium, and high. Apply it on each attribute of any dataset to create a new data frame. 'discrete' with Categorical variables and the class label.
6. Create a simple scatter plot using any dataset using 'dplyr' library. Use the same data to indicate distribution densities using box whiskers.
7. Write R Programs to implement k-means clustering, k-medoids clustering and density based clustering on any datasets.
8. Write a R Program to implement decision trees using 'reading Skills' dataset.
9. Implement decision trees using any dataset using package party and 'rpart'.
10. Generate top 5 association rules using apriori.
11. Generate top 5 association rules using ECLAT.
12. Write an R program to implement Naïve bayes Classification.

	Pithapur Rajahs Government College(A) Kakinada	Program: II B.Sc. (Data Science) Semester : III
	Course Name: WEB TECHNOLOGIES	Credits: 3
Course 8	Hours Allocated: 3hrs/week	

Course Objectives:

By the end of this course, students will be able to:

- Understand HTML structure, tags, and attributes for web page development.
- Apply CSS styling to enhance layout, text, and visual presentation.
- Use JavaScript for client-side scripting and dynamic web interactions.
- Implement DHTML techniques for responsive and interactive web elements.
- Learn XML basics for structured data representation in web applications.

Course Outcomes (Learning Outcomes):

After completing this course, students will be able to:

- Design static web pages using HTML with text, links, lists, tables, and images.
- Style web pages using CSS for backgrounds, fonts, layouts, and responsive design.
- Develop interactive features using JavaScript (variables, functions, DOM manipulation).
- Create dynamic web effects like rollover buttons, form validation, and moving elements.
- Define and present structured data using XML and understand its role in web services.

UNIT I

HTML: HTML Syntax, Tags and Attributes, Document body, Text, Headers, Hyperlinks, Adding more Formatting, Lists, Tables, Grouping, Images. More HTML: Multimedia Objects, Forms.

UNIT II

Cascading Style Sheets: Introduction, Syntax, Selectors, Background Cursors, Text Fonts, Lists, Tables, Box Model, Using Styles, Simple Examples, Creation of Own Styles, Properties and Values In Styles, Formatting Blocks of Information, Layers.

UNIT III

Introduction to JavaScript: What is DHTML, JavaScript Basics, Variables, String Manipulations, Mathematical Functions, Statements, Operators, Arrays and Functions.

UNIT IV

DHTML with JavaScript: Data Validation, Opening A New Window, Messages and Confirmations, Status Bar, Dynamic Content Updates, Rollover Buttons, Moving Images.

UNIT V

XML: Defining Data for Web Applications, Basic XML, Document Type Definition, Presenting XML, Document Object Model, Web Services.

TEXT BOOKS:

1. Harvey M. Deitel and Paul J. Deitel, “Internet & World Wide Web How to Program”, 4/e, Pearson Education.
2. Uttam Kumar Roy, WebTechnologies from Oxford University Press Student Activities.

Co-curricular Activities:

- We for Web – Students with right mix of skills are formed as groups to develop websites.
- Web Ninja- A platform to showcase creative websites developed by students to their peers.

Assessment Methods:

- Formal Examinations.
- Lab Practical Examination.
- Presentations.
- Simple Project.

	Pithapur Rajahs Government College(A) Kakinada Department of Computer Science	Program: II B.Sc. (Data Science) Semester : III
	Course Name: WEB TECHNOLOGIES Hours Allocated: 3hrs/week	

MODEL BLUE PRINT

EXAM STRUCTURE:

Section	Questions Given	To Answer	Marks Each	Total
Section-I (Part-A and Part-B Essay Questions)	6	3	10	30
Section-II (Section-II Short Questions)	7	4	5	20

UNIT-WISE DISTRIBUTION:

UNIT	Essay Qs (10m)	Short Qs (5m)	Total Marks
I	2	1	25
II	1	2	20
III	1	1	15
IV	1	1	15
V	1	2	20

Total Questions: 6 (Essay) + 7 (Short) = 13

Questions to Answer: 3 (Essay) + 4 (Short) = 7

Total Marks before Choice: 95

Final Exam Marks: 50

Choice Percentage: 47.36% $[(95-50)/95 \times 100]$

 Course 8	Pithapur Rajahs Government College(A) Kakinada		Program: II B.Sc. (Data Science) Semester : III
	Course Name: WEB TECHNOLOGIES		
	Hours Allocated: 3hrs/week		Credits: 3
	Model Paper		
	Time: 2hrs.	Max. Marks: 50	

SECTION-I

Answer any THREE questions (Must attempt at least one from each Part). Each question carries 10 Marks.

PART-A

1. Explain the role of forms in HTML. Illustrate with an example.
2. Discuss the CSS box model with a neat diagram.
3. Write notes on string manipulation and mathematical functions in JavaScript.

PART-B

4. Explain with examples how alert(), confirm(), and prompt() dialog boxes are used for messages and confirmations in JavaScript
5. Discuss the role of Document Type Definition (DTD) in XML.
6. Discuss different types of HTML lists with examples.

SECTION-II

Answer any FOUR questions. Each question carries 5 Marks.

7. What are multimedia objects in HTML? Give examples.
8. What is the difference between ID and class selector?
9. Write CSS code to style a block of text with font-size, color, and alignment.
10. What is DHTML? How does it differ from HTML?
11. Explain with example how to create rollover buttons.
12. Differentiate between HTML and XML.
13. What are web services? How are they related to XML?

	Pithapur Rajahs Government College(A) Kakinada	Program: II B.Sc. (Data Science) Semester : III
	Course Name: WEB TECHNOLOGIES LAB	Credits: 1
Course 8	Hours Allocated: 2 hrs./week	

1. Design web pages for your college containing a description of the courses, departments, faculties, library etc., use href, list tags.
2. Create your class timetable using table tag.
3. Create a feedback form for your curriculum. Use textbox, text area, checkbox, radio button etc.
4. Create your resume using HTML tags. Experiment with colours, text, link, size and also other tags you studied.
5. Design a web page of your College Day Celebrations with an attractive background colour, text colour, images, font etc. Use CSS.
6. Use External CSS to format your class timetable as you created.
7. Use External, Internal, and Inline CSS to format web page of your start up.
8. Develop a JavaScript to display your admission details in the college.
9. Develop simple calculator for addition, subtraction, multiplication and division operation using JavaScript.
10. Create HTML page with JavaScript which takes integer number as input and tells whether the number is odd or even.
11. Create HTML page that contains form for registration of your participation in a hackathon. Use relevant fields for input data. Write a JavaScript code to combine and display the input information when the button is clicked.
12. Create a login form with id and password. Perform input validation

SEMESTER-IV

	Pithapur Rajahs Government College(A) Kakinada Department of Computer Science	Program: II B.Sc. (Data Science) Semester : IV
Course 9	Course Name: DATA VISUALIZATION USING TABLEAU	
		Hours Allocated: 3hrs/week

Course Objectives:

- To introduce students to data connection techniques and data preparation in Tableau.
- To develop students' ability to create and interpret various chart types and visualizations.
- To enable students to perform advanced data manipulations using calculated fields and table calculations.
- To teach students how to integrate geographic data and build interactive map-based visualizations.
- To prepare students for real-world data analysis through parameterized and ad-hoc reporting in Tableau Server.

Course Outcomes:

By the end of this course, students will be able to:

- Connect Tableau to various data sources and perform data joining and blending operations.
- Build and customize a wide range of data visualizations including bar charts, scatter plots, maps, and Gantt charts.
- Implement calculated fields and use table calculations to enhance visual insights.
- Create interactive geographic visualizations using custom map data and location plotting.
- Design self-service dashboards and conduct ad-hoc analysis using parameters and forecasting tools in Tableau Server.

UNIT - I

Creating Visual Analytics with tableau desktop, connecting to your data-How to Connect to your data, What are generated Values? Knowing when to use a direct connection, Joining tables with tableau, blending different data sources in a single worksheet.

UNIT - II

Building your first Visualization- How Me works- Chart types, Text Tables, Maps, bar chart, Line charts, Area Fill charts and Pie charts, scatter plot, Bullet graph, Gantt charts, Sorting data in tableau, Enhancing Views with filters, sets groups and hierarchies.

UNIT - III

Creating calculations to enhance your data- What is aggregation, what are calculated values and table calculations, Using the calculation dialog box to create, Building formulas using table calculations, Using table calculation functions

UNIT - IV

Using maps to improve insights-Create a Standard Map View, Plotting your own locations on a map, Replace Tableau's standard maps, Shaping data to enable Point-to-Point mapping.

UNIT - V

Developing an Adhoc analysis environment- generating new data with forecasts, providing self evidence adhoc analysis with parameters, Editing views in tableau Server.

TEXT BOOKS:

1. Tableau your data-Daniel G. Murray and the Inter works BI team, Wiley Publications
2. Tableau Data Visualizaton Cookbook, Ashutosh Nandeshwar, PACKT publishing.
3. Storytelling with Data: A Data Visualization Guide for Business Professionals by Cole NussbaumerKnaflie (2014)
4. ggplot2: Elegant Graphics for Data Analysis by Hadley Wickham (2009)

REFERENCE BOOKS:

1. Designing Data Visualizations: Representing Informational Relationships by Noah Iliinsky, Julie Steele (2011)
2. Alexandru C. Telea – “Data Visualization principles and practice” Second Edition, CRC Publications
3. Joshua N. Millign–“ Learning Tableau -2019” – Third Edition- Packt publications

Student Activity

Create a sample super store data set and visualize the following requirements

General Requirements

1. Dashboard size is 1250px wide by 750px tall.
2. Prefer using containers
3. The dashboard has a total of 5 containers (no more, no less)
4. The Filter Pane
5. Each filter has some padding

1. Charts Pane Requirement

1. All 3 charts must be in one vertical container
 2. Do proper formatting
 3. Each chart has some padding between them and other objects
 4. Each chart has a grey border, slightly darker than the Pane background color.
 5. The Pane under the Title has a border
- 2.** The second graph should have the title as “Sales” and should show monthly sales per year. Make sure it is an area chart with proper formatting.
- 3.** The third graph should the title as “Profit” and should show monthly profit per year. Make sure it is an area chart with proper formatting.

Continuous assessment:

Let the students be tested in the following questions from each unit

1. What are generated values? Join tables using Tableau
2. Create any visualization charts using Chart types, Text Tables, Maps, bar chart, Line charts, Area Fill charts and Pie charts, scatter plot etc.,
3. What is aggregation, what are calculated values and table calculations?
4. Using Standard Map View, Plot your own locations on a map
5. Develop an Adhoc analysis environment.

	Pithapur Rajahs Government College(A) Kakinada Department of Computer Science	Program: II B.Sc. (Data Science) Semester : IV
Course 9	Course Name: DATA VISUALIZATION USING TABLEAU Hours Allocated: 3hrs/week	
		Credits: 3

MODEL BLUE PRINT

EXAM STRUCTURE:

Section	Questions Given	To Answer	Marks Each	Total
Section-I (Part-A and Part-B Essay Questions)	6	3	10	30
Section-II (Section-II Short Questions)	7	4	5	20

UNIT-WISE DISTRIBUTION:

UNIT	Essay Qs (10m)	Short Qs (5m)	Total Marks
I	1	2	20
II	2	1	25
III	1	1	15
IV	1	1	15
V	1	2	20

Total Questions: 6 (Essay) + 7 (Short) = 13

Questions to Answer: 3 (Essay) + 4 (Short) = 7

Total Marks before Choice: 95

Final Exam Marks: 50

Choice Percentage: 47.36% $[(95-50)/95 \times 100]$

	Pithapur Rajahs Government College(A) Kakinada Department of Computer Science	Program: II B.Sc. (Data Science) Semester : IV
Course 9	Course Name: DATA VISUALIZATION USING TABLEAU	Credits: 3
	Hours Allocated: 3hrs/week	
Model Paper		
Max. Time: 2 Hrs		Max. Marks: 50

SECTION-I

Answer any THREE questions (Must attempt at least one from each Part). Each question carries 10 Marks. 3X10=30

PART-A

1. What is the difference between joining and blending data in Tableau?
2. Describe the steps to create a bar chart and a line chart in Tableau.
3. Explain how filters, groups, and sets help in improving a Tableau view.

PART-B

4. What are calculated fields? How do you create and use them in Tableau?
5. How can maps be created in Tableau? Explain the steps with an example.
6. What is ad-hoc analysis? How can we use parameters in Tableau for this purpose?

SECTION-II

Answer any FOUR questions. Each question carries 5 Marks. 4X5=20

7. What is a worksheet in Tableau?
8. What are generated values in Tableau?
9. When would you use a pie chart instead of a bar chart?
10. What is aggregation in Tableau?
11. What does point-to-point mapping mean in Tableau?
12. How can you plot your own locations on a map in Tableau?
13. What is the purpose of forecasting in Tableau?

	Pithapur Rajahs Government College(A) Kakinada Department of Computer Science	Program: II B.Sc. (Data Science) Semester : IV
Course 9	Course Name: Data Visualization Using Tableau Lab	
	Hours Allocated: 2hrs/week	Credits: 1

Lab Programs List

1. Connect to data Sources
2. Create Univariate Charts
3. Create Bivariate and Multivariate charts
4. Create Maps
5. Calculate user-defined fields
6. Create a workbook data extract
7. Save a workbook on a Tableau server and web
8. Export images, data.

	Pithapur Rajahs Government College(A) Kakinada Department of Computer Science	Program: II B.Sc. (Data Science) Semester : IV
Course 10	Course Name: DATA VISUALIZATION USING PYTHON	
Hours Allocated: 3hrs/week		Credits: 3

Course Objectives:

- Understand the fundamentals of Data Science, Exploratory Data Analysis (EDA), and the data science process.
- Gain proficiency in Python programming for data analysis using Jupyter Notebook.
- Learn to use essential Python libraries such as NumPy, pandas, matplotlib, seaborn, SciPy, scikit-learn, and statsmodels.
- Perform data cleaning, preparation, and transformation using pandas.
- Develop skills in data wrangling and visualization through various plotting libraries.

Course Outcomes:

- Describe the data science workflow and explain the role of Python and Jupyter Notebook in the data analysis process.
- Demonstrate the use of NumPy and pandas for efficient array operations and data manipulation.
- Read, write, and process data from various sources including text, binary, databases, and web APIs.
- Clean and transform datasets using pandas tools for handling missing values, string manipulation, and reshaping.
- Visualize data using matplotlib, pandas plotting, and seaborn for both categorical and numerical data.

Unit 1

Introduction: Introduction to Data Science, Exploratory Data Analysis and Data Science Process. Motivation for using Python for Data Analysis, Introduction of Python Jupyter Notebook. Essential Python Libraries: NumPy, pandas, matplotlib, seaborn.

Unit 2

Getting Started with Pandas: Arrays and vectorized computation, Introduction to pandas Data Structures, Essential Functionality, Summarizing and Computing Descriptive Statistics. Data Loading, Storage and File Formats. Reading and Writing Data in Text Format, Binary Data Formats, Interacting with Web APIs, Interacting with Databases Data Cleaning and

Preparation. Handling Missing Data, Data Transformation, String Manipulation.

Unit 3

Data Wrangling: Hierarchical Indexing, Combining and Merging Data Sets Reshaping and Pivoting. Data Visualization matplotlib: Basics of matplotlib, plotting with pandas and seaborn.

Unit 4

Data Aggregation and Group operations: Group by Mechanics, Data aggregation, General split-apply-combine, Pivot tables and cross tabulation

Time Series Data Analysis: Date and Time Data Types and Tools, Time series Basics, date Ranges, Frequencies and Shifting, Periods and Periods Arithmetic, Resampling and Frequency conversion, Moving Window Functions.

Unit 5

Advanced Pandas: Categorical Data: cleaning data and visualization techniques, Advanced GroupBy methods, Use Techniques for Method Chaining.

Textbook:

1. McKinney, W.(2017). Python for Data Analysis: Data Wrangling with Pandas, NumPy and IPython. 2nd edition. O'Reilly Media.

Reference:

1. O'Neil, C., & Schutt, R. (2013). Doing Data Science: Straight Talk from the Frontline O'Reilly Media.

	Pithapur Rajahs Government College(A) Kakinada Department of Computer Science	Program: II B.Sc. (Data Science) Semester : IV
Course 10	Course Name: DATA VISUALIZATION USING PYTHON	
	Hours Allocated: 3hrs/week	Credits: 3

MODEL BLUE PRINT

EXAM STRUCTURE:

Section	Questions Given	To Answer	Marks Each	Total
Section-I (Part-A and Part-B Essay Questions)	6	3	10	30
Section-II (Section-II Short Questions)	7	4	5	20

UNIT-WISE DISTRIBUTION:

UNIT	Essay Qs (10m)	Short Qs (5m)	Total Marks
I	1	2	20
II	2	1	25
III	1	1	15
IV	1	2	20
V	1	1	15

Total Questions: 6 (Essay) + 7 (Short) = 13

Questions to Answer: 3 (Essay) + 4 (Short) = 7

Total Marks before Choice: 95

Final Exam Marks: 50

Choice Percentage: 47.36% $[(95-50)/95 \times 100]$

	Pithapur Rajahs Government College(A) Kakinada Department of Computer Science	Program: II B.Sc. (Data Science) Semester : IV
Course 10	Course Name: DATA VISUALIZATION USING PYTHON	Credits: 3
	Hours Allocated: 3hrs/week	
Model Paper		
Max. Time: 2 Hrs		Max. Marks: 50

SECTION-I

Answer any THREE questions (Must attempt at least one from each Part). Each question carries 10 Marks. 3X10=30

PART-A

1. Explain the Data Science process and discuss how Python helps in data analysis.
2. What is pandas? Describe its data structures and basic functionalities with examples.
3. Discuss the process of cleaning and transforming data using pandas. Include handling missing values and string operations.

PART-B

4. Describe data wrangling in pandas and explain techniques like merging, reshaping, and pivoting data.
5. What is the split-apply-combine strategy in pandas? Explain groupby operations with examples.
6. Discuss advanced pandas features like method chaining, categorical data handling, and advanced groupby techniques.

SECTION-II

Answer any FOUR questions. Each question carries 5 Marks. 4X5=20

7. What is Jupyter Notebook used for?
8. How can we handle missing data in pandas?
9. What is hierarchical indexing in pandas?
10. Define resampling in the context of time series analysis.
11. Why is groupby() used in Pandas?
12. How can you plot your own locations on a map in Tableau?
13. What is the purpose of forecasting in Tableau?

	Pithapur Rajahs Government College(A) Kakinada Department of Computer Science	Program: II B.Sc. (Data Science) Semester : IV
Course 10	Course Name: Data Visualization Using Python Lab	
	Hours Allocated: 2hrs/week	Credits: 1

Lab List

1. Practicals based on NumPy ndarray
2. Practicals based on Pandas Data Structures
3. Practicals based on Data Loading, Storage and File Formats
4. Practicals based on Interacting with Web APIs
5. Practicals based on Data Cleaning and Preparation
6. Practicals based on Data Wrangling
7. Practicals based on Data Visualization using matplotlib
8. Practicals based on Data Aggregation
9. Practicals based on Time Series Data Analysis

	Pithapur Rajahs Government College(A) Kakinada Department of Computer Science	Program: II B.Sc. (Data Science) Semester: IV
Course 11	Course Name: Introduction to SQL & Advanced Tableau	
	Hours Allocated: 3hrs/week	Credits: 3

Course Objectives:

- Understand the fundamental concepts of data, databases, and database management systems.
- Analyze and design databases using the Entity-Relationship (ER) model.
- Develop proficiency in Structured Query Language (SQL) for managing and manipulating databases.
- Apply data visualization principles using appropriate chart types for effective data communication.
- Design and develop interactive dashboards using Tableau, incorporating best practices.

Course Outcomes:

- Differentiate between data, information, and databases, and describe the components and functions of a DBMS.
- Construct ER diagrams and convert them into normalized relational tables.
- Write SQL queries for data definition, manipulation, and retrieval, including joins, subqueries, and set operations.
- Apply appropriate data visualization techniques (e.g., bar charts, heat maps, scatter plots) for various types of data insights.
- Design interactive and user-friendly dashboards in Tableau following best practices and design principles.

Unit - I

Overview of Database Management System: Introduction to data, information, database, database management system, DBMS software's, keys in DBMS. the building blocks of an entity relationship diagram, classification of entity sets, attribute classification, relationship degree, relationship classification, reducing ER diagram to tables,

Unit - II

Structured Query Language: Introduction, History of SQL Standard, Commands in SQL, Data Types in SQL, Data Definition Language, Data Manipulation Language, database constraints,

Aggregate functions, Join Operation, Set Operations, Views. SQL queries, sub queries and correlated queries.

Unit - III

Optimal visualization types – bar chart, pie chart, bubble chart, bullet chart, scatter plot, line chart, heat map, tree map Maps- geographical locational plotting, Binning values, calculated fields, Table calculations.

Unit - IV

Dashboard development, Dashboard design principles, dashboard interactivity, connected “drill-down” dash boards Best Practices.

Unit - V

Advanced Tableau, Large datasets, Fiscal Year Calculations, Parameters, tableau scripting, integration of tableau with R programming.

Textbook:

1. Show me the Numbers: Designing Tables and Graphs to Enlighten by Stephen Few
2. The Data Loom: Weaving Understanding by Thinking Critically and Scientifically with Data by Stephen Few

Reference:

1. The Big Book of Dashboards: Visualizing your Data using Real- World Business Scenarios by Steve Wexler, Jeffrey Shaffer, and Andy Cotgreave.

 Pithapur Rajahs Government College(A) Kakinada Department of Computer Science	Program: II B.Sc. (Data Science) Semester : IV	
		Course Name: Introduction to SQL & Advanced Tableau
Course 11	Hours Allocated: 3hrs/week	Credits: 3

MODEL BLUE PRINT

EXAM STRUCTURE:

Section	Questions Given	To Answer	Marks Each	Total
Section-I (Part-A and Part-B Essay Questions)	6	3	10	30
Section-II (Section-II Short Questions)	7	4	5	20

UNIT-WISE DISTRIBUTION:

UNIT	Essay Qs (10m)	Short Qs (5m)	Total Marks
I	1	2	20
II	2	1	25
III	1	2	20
IV	1	1	15
V	1	1	15

Total Questions: 6 (Essay) + 7 (Short) = 13

Questions to Answer: 3 (Essay) + 4 (Short) = 7

Total Marks before Choice: 95

Final Exam Marks: 50

Choice Percentage: 47.36% $[(95-50)/95 \times 100]$

	Pithapur Rajahs Government College(A) Kakinada Department of Computer Science	Program: II B.Sc. (Data Science) Semester : IV
Course 11	Course Name: Introduction to SQL & Advanced Tableau	
	Hours Allocated: 3hrs/week	Credits: 3
Model Paper		
Max. Time: 2 Hrs		Max. Marks: 50

SECTION-I

Answer any THREE questions (Must attempt at least one from each Part). Each question carries 10 Marks. 3X10=30

PART-A

1. Describe the components of an Entity Relationship (ER) diagram. Explain how ER diagrams are converted into relational tables.
2. Write and explain the different types of SQL commands with suitable examples (DDL, DML, DCL, TCL).
3. Explain the different types of joins in SQL. Provide examples for each join type.

PART-B

4. Compare and contrast different chart types used in data visualization.
5. What are the key principles for designing an effective dashboard in Tableau? Discuss with examples.
6. Describe how Tableau can be integrated with R programming. What are the benefits of this integration?

SECTION-II

Answer any FOUR questions. Each question carries 5 Marks. 4X5=20

7. What is a DBMS? Give one example.
8. Define a primary key and a foreign key.
9. What are the different types of attributes in an ER model?
10. List any three types of charts used in Tableau.
11. Define “calculated field” in Tableau.
12. What is the use of filters in a Tableau dashboard?
13. What is the function of Tableau Server?

	Pithapur Rajahs Government College(A) Kakinada Department of Computer Science	Program: II B.Sc. (Data Science) Semester : IV
Course 11	Course Name: Introduction to SQL & Advanced Tableau Lab <hr/> Hours Allocated: 2hrs/week	

Lab List

Consider Following Databases Convert Entities And Relationships To Relation Table For A Given Scenario.

1. COLLEGE DATABASE:

Student (Stno, Sname, Address, Phone, Gender)

Course(Courseid, Sem, Sec)

CLASS (Stno, Courseid)

SUBJECT (Subcode, Title, Sem, Credits)

MARKS (Stno, Subcode, Courseid, Test1, Test2, Test3, Total)

2. COMPANY DATABASE:

EMPLOYEE (SSN, Name, Address, Sex, Salary, Superssn, Dno)

DEPARTMENT (Dno, Dname, Mgrssn, Mgrstartdate)

DLOCATION (Dno,Dloc)

PROJECT (Pno, Pname, Plocation, Dno)

WORKS_ON (SSN, Pno, Hours)

3. Consider A College Database Schema

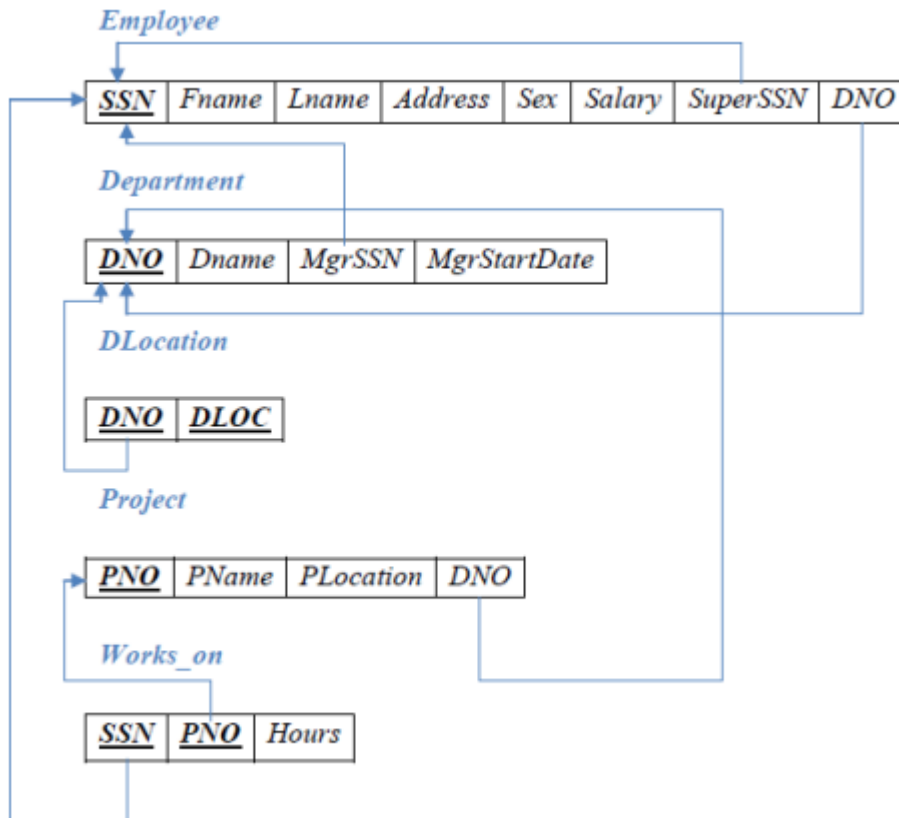

a. Create above tables with relevant Primary Key, Foreign Key and other constraints

b. Populate the tables with data

4. Perform queries to generate outputs:

1. Display all the details of all employees working in the company.
2. Display ssn, lname, fname, address of employees who work in department no 7
3. Retrieve the Birthdate and Address of the employee whose name is 'Franklin T.Wong'
4. Retrieve the name and salary of every employee.
5. Retrieve all distinct salary values
6. Retrieve all employee names whose address is in 'Bellaire'
7. Retrieve all employees who were born during the 1950s

8. Retrieve all employees in department 5 whose salary is between 50,000 and 60,000 (inclusive)

5. Perform the following queries

1. Retrieve the names of all employees who do not have supervisors
2. Retrieve SSN and department name for all employees
3. Retrieve the name and address of all employees who work for the 'Research' department
4. For every project located in 'Stafford', list the project number, the controlling department number, and the department manager's last name, address, and birth date.
5. For each employee, retrieve the employee's name, and the name of his or her immediate supervisor.
6. Retrieve all combinations of Employee Name and Department Name
7. 7. Make a list of all project numbers for projects that involve an employee whose last name is 'Narayan' either as a worker or as a manager of the department that controls the project.
8. 8. Increase the salary of all employees working on the 'ProductX' project by 15%. Retrieve employee name and increased salary of these employees.
9. 9. Retrieve a list of employees and the project name each works in, ordered by the employee's department, and within each department ordered alphabetically by employee first name.
10. 10. Select the names of employees whose salary does not match with salary of any employee in department.

6. Perform following queries :

1. Retrieve the employee numbers of all employees who work on project located in Bellaire, Houston, or Stafford.
2. Find the sum of the salaries of all employees, the maximum salary, the minimum salary, and the average salary. Display with proper headings
- 3 Find the sum of the salaries and number of employees of all employees of the 'Marketing' department, as well as the maximum salary, the minimum salary, and the average salary in this department.
4. Select the names of employees whose salary is greater than the average salary of all employees in department 10.
5. Delete all dependents of employee whose ssn is '123456789'.

6. Perform a query using alter command to drop/add field and a constraint in Employee table.
7. Format your data using filters with colors
8. create dashboards and stories.
9. Distribute and publish your visualization
10. create advanced mapping
 - point-to-point map
 - Dual axis map
11. Calculate distance between two points on a map.

SEMESTER-V

	Pithapur Rajahs Government College(A) Kakinada Department of Computer Science	Program: III B.Sc. (Data Science) Semester : V
Course 12	Course Name: SUPERVISED ML WITH PYTHON	
	Hours Allocated: 3hrs/week	Credits: 3

Course Objectives:

- Understand the basic concepts and types of machine learning.
- Learn how to use Python libraries like NumPy and Matplotlib for data analysis.
- Learn how to prepare and clean data for machine learning.
- Apply machine learning techniques to real-world datasets.
- Evaluate and compare different machine learning models.

Course Outcomes:

- Describe the basic concepts and steps in machine learning.
- Use Python tools like NumPy and Matplotlib for data handling and visualization.
- Build and use the k-Nearest Neighbours (k-NN) algorithm for classification.
- Create and visualize decision trees for classification problems.
- Apply the Naïve Bayes algorithm for text and numeric data classification.

UNIT - I

Machine Learning Basics: What is machine learning? Key terminology, Key tasks of machine learning, How to choose right algorithm, steps in developing a machine learning, why python? Getting started with Numpy library, Scikit-learn library: Classifying with k- Nearest Neighbors: The k-Nearest Neighbors classification algorithm, Parsing and importing data from a text file, Normalizing numeric values.

UNIT - II

Splitting datasets one feature at a time-Decision trees: Introducing decision trees, measuring consistency in a dataset (Entropy, Information-gain, Gini Index), using recursion to construct a decision tree, Stopping condition, plotting trees in Matplotlib.

UNIT - III

Classifying with probability theory-Naïve Bayes: Using probability distributions for classification, learning the naïve Bayes classifier, Parsing data from RSS feeds, using naïve Bayes to reveal regional attitudes.

UNIT - IV

Logistic regression: Classification with logistic regression and the sigmoid function, Using optimization to find the best regression coefficients, the gradient descent optimization algorithm, Dealing with missing values in the our data.

UNIT - V

Support vector machines: Introducing support vector machines, using the SMO algorithm for optimization, using kernels to “transform” data, Comparing support vector machines with other classifiers.

TEXT BOOKS:

1. Machine learning in action, Peter Harrington by Manning publications
Supervised ML with Python Lab

	Pithapur Rajahs Government College(A) Kakinada Department of Computer Science	Program: III B.Sc. (Data Science) Semester : V
Course 12	Course Name: SUPERVISED ML WITH PYTHON	
	Hours Allocated: 3hrs/week	Credits: 3

MODEL BLUE PRINT

EXAM STRUCTURE:

Section	Questions Given	To Answer	Marks Each	Total
Section-I (Part-A and Part-B Essay Questions)	6	3	10	30
Section-II (Section-II Short Questions)	7	4	5	20

UNIT-WISE DISTRIBUTION:

UNIT	Essay Qs (10m)	Short Qs (5m)	Total Marks
I	2	2	30
II	1	1	15
III	1	1	15
IV	1	2	20
V	1	1	15

Total Questions: 6 (Essay) + 7 (Short) = 13

Questions to Answer: 3 (Essay) + 4 (Short) = 7

Total Marks before Choice: 95

Final Exam Marks: 50

Choice Percentage: 47.36% $[(95-50)/95 \times 100]$

	Pithapur Rajahs Government College(A) Kakinada Department of Computer Science	Program: III B.Sc. (Data Science) Semester : V
Course 12	Course Name: SUPERVISED ML WITH PYTHON	Semester : V
	Hours Allocated: 3hrs/week	
Model Paper		
Max. Time: 2 Hrs		Max. Marks: 50

SECTION-I

Answer any THREE questions (Must attempt at least one from each Part). Each question carries 10 Marks. 3X10=30M

PART-A

1. Define Machine Learning. Explain its key terminologies and major types of tasks it performs.
2. Explain the concept of a Decision Tree. How is it used for classification?
3. Explain how the Naïve Bayes classifier works. What assumptions does it make?

PART-B

4. Explain the k-Nearest Neighbors (k-NN) classification algorithm in detail.
5. Explain logistic regression. How is it used for binary classification?
6. Explain the Sequential Minimal Optimization (SMO) algorithm used for training SVMs

SECTION-II

Answer any FOUR questions. Each question carries 5 Marks. 4X5=20M

7. Define normalization. Why is it important in machine learning algorithms like k-NN?
8. Write a short note on NumPy and its role in Machine Learning.
9. What is a decision tree? List its main components.
10. Define entropy in the context of decision trees.
11. What is the core assumption made by the Naïve Bayes classifier?
12. What is the purpose of gradient descent in logistic regression?
13. What is the role of support vectors in an SVM model?



	Pithapur Rajahs Government College(A) Kakinada Department of Computer Science	Program: III B.Sc. (Data Science)
Course 12	Course Name: Supervised ML With Python Lab	Semester : V
	Hours Allocated: 2hrs/week	Credits: 1

Lab List

1. Implement and demonstrate the FIND-S algorithm for finding the most specific hypothesis based on a given set of training data samples. Read the training data from a CSV file. Forgiven set of training data examples stored in a .CSV file, implement and demonstrate the Candidate-Elimination algorithm to output a description of the set of all hypotheses consistent with the training examples.
2. Write a program to demonstrate the working of the decision tree based ID3 algorithm.
3. Write a program to implement the naïve Bayesian classifier for a sample training data set stored as a CSV file.
4. Assuming a set of documents that need to be classified, use the naïve Bayesian Classifier model to perform this task. Built-in Java classes/API can be used to write the program. Calculate the accuracy, precision, and recall for your dataset.

	Pithapur Rajahs Government College(A) Kakinada Department of Computer Science	Program: III B.Sc. (Data Science) Semester: V
Course 13	Course Name: Unsupervised Machine Learning with Python	
	Hours Allocated: 3hrs/week	Credits: 3

Course Objectives:

- Understand key concepts and algorithms in unsupervised learning, including clustering and association analysis.
- Learn and implement k-means, bisecting k-means, and Apriori algorithms on real-world datasets.
- Explore and apply the FP-growth algorithm for mining frequent item sets efficiently.
- Apply dimensionality reduction techniques, especially PCA, to simplify complex datasets.
- Understand and use Singular Value Decomposition (SVD) for matrix factorization and recommendation

Course Outcomes:

By the end of this course, students will be able to:

- Apply and analyze clustering algorithms like k-means and bisecting k-means.
- Use the Apriori algorithm to identify frequent item sets and generate association rules.
- Implement FP-growth to mine patterns from datasets such as clickstreams or social media feeds.
- Reduce data dimensionality using PCA and interpret the transformed data.
- Develop simple recommendation systems using SVD and collaborative filtering techniques.

UNIT - I

Unsupervised Learning: Clustering: k-means clustering algorithm, Hierarchical Clustering, Improving cluster performance with post processing, Bisecting k-means, Example: clustering points on a map

UNIT - II

Association analysis: Apriori algorithm: Association analysis, The Apriori principle, Finding frequent item sets with the Apriori algorithm, Mining association rules from frequent item sets, Market basket analysis .

UNIT - III

Finding frequent item sets: FP-growth –FP trees, Build FP-tree, mining frequent from an FP tree, finding co-occurring words in a Twitter feed, mining a click stream from a news site.

UNIT - IV

Principal component analysis: Dimensionality reduction techniques, using PCA to reduce the dimensionality of any standard dataset.

UNIT - V

Singular value decomposition: Applications of the SVD, Matrix factorization, SVD in Python, Collaborative filtering–based recommendation engines, a restaurant dish recommendation engine.

TEXT BOOKS:

1. Machine learning in action, Peter Harrington by Manning publications Unsupervised ML with Python Lab.

Student Activity

Create a Sample Superstore Dataset Dashboard

General Requirements

- Dashboard Dimensions Size: 1250px wide × 750px tall
- Use of Containers Prefer layout containers (horizontal/vertical) for organizing visual elements.
- Container Requirement Dashboard must contain exactly 5 containers (no more, no less).
- Filter Pane Include a dedicated filter pane for user interaction (e.g., filtering by category, region, or date).
- Padding Ensure each filter control has adequate padding for visual clarity and user experience.

Continuous assessment:

Let the students be tested in the following questions from each unit

- Join multiple tables using Tableau and demonstrate the use of generated values in data preparation.
- Create various visualization charts such as bar charts, line charts, pie charts, area charts, scatter plots, maps, and text tables.
- Explain and implement aggregation, calculated values, and table calculations in Tableau.
- Develop an interactive dashboard that enables ad-hoc analysis using filters and parameters.
- Present the dashboard with meaningful insights, demonstrating clear interpretation and storytelling with data.

	Pithapur Rajahs Government College(A) Kakinada Department of Computer Science	Program: III B.Sc. (Data Science) Semester: V
Course 13	Course Name: Unsupervised Machine Learning with Python	Credits: 3
	Hours Allocated: 3hrs/week	

MODEL BLUE PRINT

EXAM STRUCTURE:

Section	Questions Given	To Answer	Marks Each	Total
Section-I (Part-A and Part-B Essay Questions)	6	3	10	30
Section-II (Section-II Short Questions)	7	4	5	20

UNIT-WISE DISTRIBUTION:

UNIT	Essay Qs (10m)	Short Qs (5m)	Total Marks
I	1	2	20
II	2	1	25
III	1	1	15
IV	1	1	15
V	1	2	20

Total Questions: 6 (Essay) + 7 (Short) = 13

Questions to Answer: 3 (Essay) + 4 (Short) = 7

Total Marks before Choice: 95

Final Exam Marks: 50

Choice Percentage: 47.36% $[(95-50)/95 \times 100]$

	Pithapur Rajahs Government College(A) Kakinada Department of Computer Science	Program: III B.Sc. (Data Science)
Course 13	Course Name: Unsupervised Machine Learning with Python	Semester: V
	Hours Allocated: 3hrs/week	Credits: 3
Model Paper		
Max. Time: 2 Hrs		Max. Marks: 50

SECTION-I

Answer any THREE questions (Must attempt at least one from each Part). Each question carries 10 Marks. 3X10=30

PART-A

1. Explain the k-means clustering algorithm with a step-by-step example. How does it converge?
2. Explain the Apriori principle and how it reduces computational complexity
3. Discuss an application of association rule mining in real-world data, such as congressional voting.

PART-B

4. Compare FP-growth and Apriori algorithms in terms of efficiency and scalability.
5. Explain the concept of PCA and its role in dimensionality reduction with an example.
6. Discuss how SVD is used in collaborative filtering for recommendation engines.

SECTION-II

Answer any FOUR questions. Each question carries 5 Marks.

4X5=20

7. Define intra-cluster and inter-cluster distance.
8. What is the role of the centroid in k-means clustering?
9. Why is pruning used in the Apriori algorithm?
10. What is the main advantage of FP-growth over Apriori?
11. What is dimensionality reduction?
12. What are the three matrices involved in SVD?
13. Define matrix factorization.

	Pithapur Rajahs Government College(A) Kakinada Department of Computer Science	Program: III B.Sc. (Data Science) Semester: V
Course 13	Course Name: Unsupervised Machine Learning with Python Lab	
	Hours Allocated: 2 hrs/week	Credits: 1

Lab List

1. Implementation of K-Means Clustering
2. Implement the bisecting k-means clustering algorithm
3. Implement Apriori algorithm
4. Implement Association rule-generation functions
5. Implement FP-tree creation
6. Write a function to find all paths ending with a given item.
7. Implement Code to access the Twitter Python library
8. Implement the PCA algorithm
9. Write a program to find Rating estimation by using the SVD
10. Implement Image-compression functions using SVD.

Course 14A	Pithapur Rajahs Government College(A) Kakinada	Program: III B.Sc. (Data Science) Semester : V
	Course Name: Web Scraping with Python	
	Hours Allocated: 3hrs/week	Credits: 3

Course Objectives:

The course aims to:

1. **Understand** the principles of web scraping and crawling, and the tools required for data extraction from websites.
2. **Develop** skills in using Python libraries (BeautifulSoup, Scrapy, Requests) to create efficient and reliable scrapers.
3. **Apply** techniques to parse, process, and store structured and unstructured data in multiple formats and databases.
4. **Analyze** advanced scraping scenarios involving forms, logins, APIs, image processing, and text recognition.
5. **Evaluate** ethical, legal, and performance considerations in designing and deploying web scraping solutions.

Course Outcomes:

On successful completion of the course, students will be able to:

1. **Design** and implement web scrapers using BeautifulSoup, Scrapy, and Requests to extract structured data from websites. *(Apply)*
2. **Parse** and **organize** data from varied formats (HTML, JSON, CSV, PDF, Word) and **integrate** it with storage systems like MySQL. *(Apply)*
3. **Automate** interactions with web elements, including forms, cookies, logins, and APIs, for dynamic data collection. *(Apply/Analyze)*
4. **Implement** image processing and text recognition methods to extract information from visual content and solve CAPTCHAs. *(Apply/Create)*
5. **Assess** the legal and ethical implications of web scraping and **formulate** strategies to ensure compliance with regulations. *(Evaluate/Create)*

UNIT-1

Building Scrapers: First Web Scraper: Connecting, An Introduction to BeautifulSoup, **Advanced HTML Parsing:** Another Serving of BeautifulSoup, Regular Expressions, Regular Expressions and BeautifulSoup, Accessing Attributes, Lambda Expressions, Writing

Web Crawlers: Traversing a Single Domain, Crawling an Entire Site, Crawling Across the Internet.

UNIT-II

Web Crawling Models: Planning and Defining Objects, Dealing with Different Website Layouts, Structuring Crawlers. **Scrapy:** Installing Scrapy, Initializing a New Spider, Writing a Simple Scraper, Spidering with Rules, Creating Items, Outputting Items, The Item Pipeline, Logging with Scrapy. **Storing Data:** Media Files, Storing Data to CSV.

UNIT-III

Advanced Scraping: Reading Documents: Document Encoding, Text, CSV, PDF, Microsoft Word and .docx, Crawling Through Forms and Logins: Python Requests Library, Submitting a Basic Form, Radio Buttons, Checkboxes, and Other Inputs, Submitting Files and Images, Handling Logins and Cookies.

UNIT-IV

Crawling Through APIs: A Brief Introduction to APIs, Parsing JSON, Undocumented APIs, Documenting Undocumented APIs, Finding and Documenting APIs Automatically.

Image Processing and Text Recognition: Overview of Libraries, Pillow, Processing Well-Formatted Text, Reading CAPTCHAs and Training Tesseract, Retrieving CAPTCHAs and Submitting Solutions.

UNIT-V

Avoiding Scraping Traps: A Note on Ethics, Looking like a Human, Common Form Security Features, The Human Checklist. Testing Your Website with Scrapers: An Introduction to Testing, Python unit test Testing with Selenium, The Legalities and Ethics of Web Scraping: Trademarks, Copyrights, Patents, Trespass to Chattels, The Computer Fraud and Abuse Act, robots.txt and Terms of Service, Three Web Scrapers

Text Books:

1. “*Web Scraping with Python*”, by Ryan Mitchell, 2nd Edition, O'Reilly Media, Inc.,2018.
2. “*Hands-On Web Scraping with Python*”, by Anish Chapagain, Packt Publishing, 2019.

References:

1. “*Getting Structured Data from the Internet*”, by Jay M. Patel, Apress, 2020

2. *“Python Web Scraping Cookbook”*, by Michael Heydt, Packt Publishing, 2018.
3. *“Web Scraping with Python*, by Richard Lawson”, Packt Publishing, 2015.

CO-CURRICULAR ACTIVITIES:

- Quiz Competition
- Expert Lectures
- Seminars

EXTRA CURRICULAR ACTIVITIES:

- Formal Examination
- Lab Practical
- Presentation
- Simple Projects

	Pithapur Rajahs Government College(A) Kakinada Department of Computer Science	Program: III B.Sc. (Data Science) Semester : V
	Course Name: Web Scraping with Python Hours Allocated: 3hrs/week	

MODEL BLUE PRINT

EXAM STRUCTURE:

Section	Questions Given	To Answer	Marks Each	Total
Section-I (Part-A and Part-B Essay Questions)	6	3	10	30
Section-II (Section-II Short Questions)	7	4	5	20

UNIT-WISE DISTRIBUTION:

UNIT	Essay Qs (10m)	Short Qs (5m)	Total Marks
I	1	2	20
II	2	1	25
III	1	2	20
IV	1	1	15
V	1	1	15

Total Questions: 6 (Essay) + 7 (Short) = 13

Questions to Answer: 3 (Essay) + 4 (Short) = 7

Total Marks before Choice: 95

Final Exam Marks: 50

Choice Percentage: 47.36% $[(95-50)/95 \times 100]$

 Course 14A	Pithapur Rajahs Government College(A) Kakinada Department of Computer Science	Program: III B.Sc. (Data Science) Semester : V
	Course Name: Web Scraping with Python	
	Model Paper	
	Time: 2hrs.	Max. Marks: 50

SECTION – I

Answer any THREE questions (Must attempt at least one from each Part). Each question carries **10 Marks**.

PART – A

1. Explain the steps to build your first web scraper using Python. Illustrate how to connect to a webpage, parse HTML using BeautifulSoup, and extract specific tags with examples.
2. Describe the architecture of the Scrapy framework. Write the steps for creating a new Scrapy spider, defining items, and outputting data to a CSV file.
3. Explain the process of submitting a form using the Python Requests library. Provide an example for handling radio buttons, checkboxes, and file uploads.

PART – B

4. What are undocumented APIs? Explain methods to find and document them. Write a Python example to parse JSON data returned from an API.
5. Discuss the ethical and legal considerations in web scraping. How does robots.txt influence scraper design? Provide relevant examples.
6. Explain the use of the Natural Language Toolkit (NLTK) in processing scraped text. Write code to tokenize and summarize text content from a webpage.

SECTION – II

Answer any FOUR questions. Each question carries **5 Marks**.

7. Differentiate between HTML parsing using BeautifulSoup and regex. Give one example for each.
8. List and explain any five Scrapy Item Pipeline components and their uses.
9. Write Python code to read data from a PDF file and extract text content.
10. Explain the role of the Pillow library in image processing. Give an example of resizing an image.
11. What is Tesseract OCR? Write a short Python example to read text from an image.
12. What are scraping traps? Mention three techniques to avoid them.
13. Write Python code to extract all hyperlinks (<a> tags) from a given webpage using BeautifulSoup.

	Pithapur Rajahs Government College(A) Kakinada	Program: III B.Sc. (Data Science) Semester : V
Course 14A	Course Name: Web Scraping with Python Lab	
	Hours Allocated: 2 hrs/week	Credits: 1

1. Write a Python program to test if a given page is found or not on the server.
2. Write a Python program to download and display the content of robot.txt for en.wikipedia.org.
3. Write a Python program to get the number of datasets currently listed on data.gov.
4. Write a Python program to convert an address into geographic coordinates (like latitude and longitude).
5. Write a Python program to display the name of the most recently added dataset on data.gov.
6. Write a Python program to extract h1 tag from example.com.
7. Write a Python program to extract and display all the header tags from en.wikipedia.org/wiki/Main_Page.
8. Write a Python program to extract and display all the image links from a website.
9. Write a Python program to get 90 days of visits broken down by browser for all sites on data.gov.
10. Write a Python program to that retrieves an arbitrary Wikipedia page of "Python" and creates a list of links on that page.
11. Write a Python program to check whether a page contains a title or not.
12. Write a Python program to list all language names and number of related articles in the order they appear in wikipedia.org.
13. Write a Python program to get the number of followers of a given twitter account.
14. Write a Python program to find the live weather report (temperature, wind speed, description and weather) of a given city.
15. Write a Python program to display the date, days, title, city, country of next 25 events.
16. Write a Python program to download IMDB's Top 250 data (movie name, Initial release, director name and stars).
17. Write a Python program to get movie name, year and a brief summary of the top 10 random movies.

	Pithapur Rajahs Government College(A) Kakinada Department of Computer Science	Program: III B.Sc. (Data Science) Semester: V
Course 14B	Course Name: Predictive & Advanced Analytics using R	
	Hours Allocated: 3hrs/week	

Course Objectives:

- To introduce students to the fundamental concepts and techniques used in data mining, including the KDD process, CRISP-DM, and various applications.
- To equip students with the skills to collect, clean, and visualize data, handling missing values, outliers, and relationships among variables.
- To teach students how to partition data, select models, and apply different modeling techniques like neural networks, decision trees, and regression methods.
- To familiarize students with automated data preparation techniques, as well as model evaluation, validation, and deployment strategies.
- To guide students in automating models for both categorical and continuous targets and help them evaluate and compare model performance.

Course Outcomes:

- Explain the fundamental concepts of data mining, the Data Mining Process, KDD process, CRISP-DM, and its applications across different industries.
- Effectively read and prepare data from multiple sources, apply appropriate data visualization techniques, and interpret distributions, relationships, and missing values.
- Utilize various techniques such as neural networks, decision trees, logistic regression, discriminant analysis, and more to build predictive models for different kinds of data.
- Conduct model evaluation, validation, and use techniques like CHAID and rule induction to assess model accuracy and performance.
- Apply methods for data preparation, including combining datasets, handling duplicates, dealing with missing values, and conducting data sampling.

Unit 1

Introduction to Data Mining Introduction, what is Data Mining? Concepts of Data mining, Technologies Used, Data Mining Process, KDD Process Model, CRISP – DM, Mining on various kinds of data, Applications of Data Mining, Challenges of Data Mining.

Unit 2

Data Understanding and Preparation Introduction, Reading data from various sources, Data visualization, Distributions and summary statistics, Relationships among variables, Extent of Missing Data. Segmentation, Outlier detection

Unit 3

Model development & techniques Data Partitioning, Model selection, Model Development Techniques, Neural networks, Discriminant analysis, Bayesian Networks, Linear Regression, Cox Regression.

Unit 4

Automated Data Preparation, Combining data files, Aggregate Data, Duplicate Removal, Sampling DATA, Data Caching, Partitioning data, Missing Values. Model Evaluation and Deployment Introduction, Model Validation, Rule Induction Using CHAID

Unit 5

Automating Models for Categorical (Accuracy, Precision, Recall, F1-score) and Continuous targets (MSE, RMSE, MAE, R² score), Comparing and Combining Models – Bagging and Boosting, Evaluation Charts for Model Comparison (ROC Curve), Deploying Model, Assessing Model Performance, Updating a Model

Textbook:

1. Predictive & Advanced Analytics (IBM ICE Publication).
2. Trevor Hastie, Robert Tibshirani, Jerome Friedman, The Elements of Statistical Learning- Data Mining, Inference, and Prediction, Second Edition, Springer Verlag, 2009.

Cocurricular Activities:

- Quiz Competition
- Expert Lectures
- Seminars

Assessment Methods:

- Formal Examination
- Lab Practical
- Presentation
- Simple Projects

	Pithapur Rajahs Government College(A) Kakinada Department of Computer Science	Program: III B.Sc. (Data Science) Semester: V
	Course Name: Predictive & Advanced Analytics using R	
Course 14B	Hours Allocated: 3hrs/week	Credits: 3

MODEL BLUE PRINT

EXAM STRUCTURE:

Section	Questions Given	To Answer	Marks Each	Total
Section-I (Part-A and Part-B Essay Questions)	6	3	10	30
Section-II (Section-II Short Questions)	7	4	5	20

UNIT-WISE DISTRIBUTION:

UNIT	Essay Qs (10m)	Short Qs (5m)	Total Marks
I	2	1	25
II	1	2	20
III	1	1	15
IV	1	2	20
V	1	1	15

Total Questions: 6 (Essay) + 7 (Short) = 13

Questions to Answer: 3 (Essay) + 4 (Short) = 7

Total Marks before Choice: 95

Final Exam Marks: 50

Choice Percentage: 47.36% $[(95-50)/95 \times 100]$

	Pithapur Rajahs Government College(A) Kakinada Department of Computer Science	Program: III B.Sc. (Data Science) Semester: V
Course 14B	Course Name: Predictive & Advanced Analytics using R	Semester: V
	Hours Allocated: 3hrs/week	Credits: 3
Model Paper		
Max. Time: 2 Hrs		Max. Marks: 50

SECTION-I

Answer any THREE questions (Must attempt at least one from each Part). Each question carries 10 Marks. 3X10=30

PART-A

1. Explain the Knowledge Discovery in Databases (KDD) process with a detailed diagram.
2. Compare and contrast the KDD Process Model and the CRISP-DM framework.
3. Describe the steps involved in data understanding and the importance of data visualization.

PART-B

4. Compare Decision Trees and Logistic Regression models in terms of accuracy and interpretability.
5. Describe the process of automated data preparation including duplicate removal and data partitioning.
6. Explain how models for categorical and continuous targets are automated and deployed.

SECTION-II

Answer any FOUR questions. Each question carries 5 Marks. 4X5=20

7. List any two challenges in data mining.
8. Define segmentation in the context of data mining.
9. Mention two common sources of missing data.
10. Write the name of any two supervised learning techniques.
11. What does model evaluation help determine?
12. What is data caching?
13. What is model deployment?

	Pithapur Rajah's Government College(A) Kakinada Department of Computer Science	Program: III B.Sc. (Data Science) Semester: V
Course 14B	Course Name: Predictive & Advanced Analytics using R Lab Hours Allocated: 2 hrs/week	

Lab List

Predictive And Advanced Analytics Using R Lab

Implementation of following methods using R or Matlab

1. Simple and multiple linear regression
2. Logistic regression
3. Linear discriminant analysis
4. Ridge regression
5. Cross-validation and boot strap
6. Fitting classification and regression trees
7. K-nearest neighbors
8. Principal component analysis
9. K-means clustering

	Pithapur Rajahs Government College(A) Kakinada Department of Computer Science	Program: III B.Sc. (Data Science) Semester: V
	Course Name: ADVANCED DATA ANALYSIS USING PYTHON	
	Course 15 A	Hours Allocated: 3hrs/week

Course Objectives:

- To introduce the fundamentals and evolution of Data Science, its roles, and applications across various fields.
- To equip students with techniques for effective data collection, cleaning, transformation, and pre-processing.
- To develop skills in exploratory data analysis using statistical tools and visualization techniques.
- To enable students to build and evaluate predictive models using regression techniques and pipelines.
- To understand model evaluation methods, including cross-validation and regularization techniques like Ridge Regression.

Course Outcomes:

By the end of this course, students will be able to:

- Explain the key concepts, roles, and applications of Data Science and identify security concerns in data handling.
- Apply data pre-processing techniques to clean, integrate, transform, and reduce raw data for analysis.
- Perform exploratory data analysis using descriptive statistics, correlation, and visualization tools.
- Develop, train, and evaluate regression models for predictive analytics using appropriate metrics and tools.
- Analyze model performance using cross-validation, avoid overfitting, and fine-tune models using techniques like Ridge Regression and Grid Search.

UNIT - I

INTRODUCTION: Introduction to Data Science – Evolution of Data Science – Data Science Roles – Stages in a Data Science Project – Applications of Data Science in various fields – Data Security Issues.

UNIT - II

DATA COLLECTION AND PRE-PROCESSING: Data Collection Strategies – Data Pre-Processing Overview – Data Cleaning – Data Integration and Transformation – Data Reduction – Data Discretization.

UNIT - III

EXPLORATORY DATA ANALYTICS: Descriptive Statistics – Mean, Standard Deviation, Skewness and Kurtosis – Box Plots – Pivot Table – Heat Map – Correlation Statistics – ANOVA.

UNIT - IV

MODEL DEVELOPMENT: Simple and Multiple Regression – Model Evaluation using Visualization – Residual Plot – Distribution Plot – Polynomial Regression and Pipelines – Measures for In-sample Evaluation – Prediction and Decision Making

UNIT - V

MODEL EVALUATION: Generalization Error – Out-of-Sample Evaluation Metrics – Cross Validation – Overfitting – Under Fitting and Model Selection – Prediction by using Ridge Regression – Testing Multiple Parameters by using Grid Search.

TEXTBOOKS:

1. Jojo Moolayil, “Smarter Decisions: The Intersection of IoT and Data Science”, PACKT, 2016.
2. Cathy O’Neil and Rachel Schutt , “Doing Data Science”, O’Reilly, 2015.
3. David Dietrich, Barry Heller, Beibei Yang, “Data Science and Big data Analytics”, EMC 2013
4. Raj, Pethuru, “Handbook of Research on Cloud Infrastructures for Big Data Analytics”, IGIGlobal

Student Activity

Create a sample Super Store dataset and build a 5-container dashboard (1250x750px) with a filter pane and various visualizations like bar charts, maps, and scatter plots, ensuring proper padding and interactivity.

General Requirements

1. Dashboard size must be 1250px wide by 750px tall.
2. Use containers to organize dashboard elements neatly.
3. The dashboard must contain exactly 5 containers (no more, no less).
4. Include a Filter Pane container that allows filtering by key dimensions (e.g., region, category, date).
5. Each filter element should have appropriate padding to maintain visual clarity and usability.

Continuous assessment:

Let the students be tested in the following questions from each unit

1. Explain generated values and demonstrate how to join tables using Tableau.
2. Create visualizations using various chart types including: Text Tables, Maps, Bar Charts, Line Charts, Area Fill Charts, Pie Charts, and Scatter Plots.
3. Define aggregation, calculated values, and table calculations with examples.
4. Using the Standard Map View, plot custom locations on a map.
5. Develop an Adhoc analysis environment to explore data dynamically and answer business questions.

	Pithapur Rajahs Government College(A) Kakinada Department of Computer Science	Program: III B.Sc. (Data Science) Semester: V
	Course Name: ADVANCED DATA ANALYSIS USING PYTHON	
Course 15 A	Hours Allocated: 3hrs/week	Credits: 3

MODEL BLUE PRINT

EXAM STRUCTURE:

Section	Questions Given	To Answer	Marks Each	Total
Section-I (Part-A and Part-B Essay Questions)	6	3	10	30
Section-II (Section-II Short Questions)	7	4	5	20

UNIT-WISE DISTRIBUTION:

UNIT	Essay Qs (10m)	Short Qs (5m)	Total Marks
I	1	2	20
II	1	1	15
III	1	1	15
IV	2	1	25
V	1	2	20

Total Questions: 6 (Essay) + 7 (Short) = 13

Questions to Answer: 3 (Essay) + 4 (Short) = 7

Total Marks before Choice: 95

Final Exam Marks: 50

Choice Percentage: 47.36% $[(95-50)/95 \times 100]$

	Pithapur Rajahs Government College(A) Kakinada Department of Computer Science	Program: III B.Sc. (Data Science) Semester: V
Course 15 A	Course Name: ADVANCED DATA ANALYSIS USING PYTHON	Credits: 3
	Hours Allocated: 3hrs/week	
Model Paper		
Max. Time: 2 Hrs		Max. Marks: 50

SECTION-I

Answer any THREE questions (Must attempt at least one from each Part). Each question carries 10 Marks. 3X10=30

PART-A

1. Discuss the evolution of Data Science and how it has impacted modern industries.
2. Describe different data collection strategies and their suitability for various types of projects.
3. Describe the use of visualization tools like box plots and heat maps in exploratory data analysis.

PART-B

4. Explain how residual plots help in evaluating the performance of a regression model.
5. Describe polynomial regression and how pipelines can improve model development.
6. Describe how Ridge Regression works and the role of Grid Search in parameter tuning.

SECTION-II

Answer any FOUR questions. Each question carries 5 Marks. 4X5=20

7. Define Data Science in your own words.
8. What are some common data security issues encountered in Data Science?
9. What is data pre-processing?
10. Define ANOVA and its primary purpose.
11. What is the difference between simple and multiple regression?
12. What is overfitting in machine learning?
13. What does Grid Search help to achieve in model development?

	Pithapur Rajahs Government College(A) Kakinada Department of Computer Science	Program: III B.Sc. (Data Science) Semester: V
Course 15 A	Course Name: Advanced Data Analysis Using Python Lab	
	Hours Allocated: 2hrs/week	Credits: 1

Lab List

1. Creating a Data Frame and Matrix-like Operations on a Data Frame Merging two Data Frames
2. Applying functions to Data Frames, import of external data in various file formats, statistical functions, compilation of data.
3. Using Functions with Factors
4. Accessing the Internet
5. Visualization Effects
6. Plotting with Layers
7. Overriding Aesthetics
8. Histograms and Density Charts
9. Simple Linear Regression – Fitting, Evaluation and Visualization
10. Multiple Linear Regression, Lasso and Ridge Regression
11. Use the following scenarios:
12. Use the Diabetes data set from UCI and Pima Indians Diabetes data set for performing the following:
 - a. Univariate Analysis: Frequency, Mean, Median, Mode, Variance, Standard Deviation, Skewness and Kurtosis.
 - i. Bivariate Analysis: Linear and logistic regression modeling.
 - ii. Multiple Regression Analysis

iii. Also Compare the results of the above analysis for the two data sets.

b. Data Modelling

i. Apply Bayesian and SVM techniques on Iris and Diabetes data set.

ii. Apply and explore various plotting functions on UCI datasets.

	Pithapur Rajahs Government College(A) Kakinada Department of Computer Science	Program: III B.Sc. (Data Science) Semester : V
Course 15-B	Course Name: DATA WRANGLING WITH JAVA SCRIPT	
	Hours Allocated: 3hrs/week	Credits: 3

Course Objectives:

- Introduce the concept of data wrangling and help students understand the importance of building a data pipeline using JavaScript.
- Teach the fundamentals of Node.js and how to use it to build simple reporting systems and command-line tools.
- Explain data acquisition, storage, and retrieval techniques using files, APIs, and databases like MongoDB and MySQL.
- Provide hands-on experience with exploratory coding to analyze and manipulate data using tools like Data-Forge and Nodemon.
- Develop skills in data cleaning and preparation to handle broken or inconsistent data and make it ready for analysis.

Course Outcomes:

- Describe the role of JavaScript in data wrangling and establish a basic data pipeline.
- Build and run Node.js applications for loading, processing, and displaying data.
- Import and export data using various formats like JSON, CSV, and interact with databases such as MongoDB and MySQL.
- Perform exploratory analysis on datasets using Node.js tools and generate new insights or transformed data.
- Identify and clean bad data to ensure quality and consistency in the final dataset.

UNIT - I

Getting started: establishing your data pipeline - Why data wrangling-What's data wrangling -Why use JavaScript for data wrangling- Is JavaScript appropriate for data analysis? Navigating the JavaScript ecosystem - Establishing your data pipeline

UNIT - II

Getting started with Node.js - Building a simple reporting system -Getting the code and data - Viewing the code - Installing Node.js - Running Node.js code -Running a web application -

Getting the data - Checking your Node.js version -Working with Node.js Creating a Node.js project - Creating a command-line application - Creating a code library -Creating a simple web server - Asynchronous coding - Loading a single file - Loading multiple files - Error handling - Asynchronous coding with promises - Wrapping asynchronous operations.

UNIT - III

Acquisition, storage, and retrieval -Getting the code and data -The core data representation Loading data from text files - Loading data from a REST API-Parsing JSON text data Parsing CSV text data- Importing data from databases - Importing data from MySQL - Exporting data - Exporting data to text files - Exporting data to JSON text files-Exporting data to CSV text files- Exporting data to a database - Exporting data to MySQL.

UNIT - IV

Exploratory coding - Iteration and your feedback loop - A first pass at understanding your data - Working with a reduced data sample - Prototyping with Excel - Exploratory coding with Node.js -Using Nodemon -Exploring your data - Computing the trend column - Outputting a new CSV file - Exploratory coding in the browser .

UNIT - V

Clean and prepare - The need for data cleanup and preparation - Where does broken data come from? - How does data cleanup fit into the pipeline- Identifying bad data - Techniques for fixing bad data - Cleaning our data set -Preparing our data for effective use.

TEXT BOOKS:

1. Data Wrangling with JavaScript - Ashley Davis - Manning Publication.

REFERENCE TEXTBOOKS:

1. Principles of Data Wrangling - Practical Techniques for Data Preparation- Tye Rattenbury, Joseph M. Hellerstein, Jeffrey Heer, Sean Kandel, Connor Carreras -Oreilly Publication.
2. Data Wrangling with Python - Jacqueline Kazil, Katharine Jarmul 2016-Oreilly Publication.

	Pithapur Rajahs Government College(A) Kakinada Department of Computer Science	Program: III B.Sc. (Data Science) Semester : V
	Course Name: DATA WRANGLING WITH JAVA SCRIPT	
Course 15-B	Hours Allocated: 3hrs/week	Credits: 3

MODEL BLUE PRINT

EXAM STRUCTURE:

Section	Questions Given	To Answer	Marks Each	Total
Section-I (Part-A and Part-B Essay Questions)	6	3	10	30
Section-II (Section-II Short Questions)	7	4	5	20

UNIT-WISE DISTRIBUTION:

UNIT	Essay Qs (10m)	Short Qs (5m)	Total Marks
I	1	1	15
II	2	2	30
III	1	2	20
IV	1	1	15
V	1	1	15

Total Questions: 6 (Essay) + 7 (Short) = 13

Questions to Answer: 3 (Essay) + 4 (Short) = 7

Total Marks before Choice: 95

Final Exam Marks: 50

Choice Percentage: 47.36% $[(95-50)/95 \times 100]$

	Pithapur Rajahs Government College(A) Kakinada Department of Computer Science	Program: III B.Sc. (Data Science) Semester : V
Course 15-B	Course Name: DATA WRANGLING WITH JAVA SCRIPT	
	Hours Allocated: 3hrs/week	Credits: 3
Model Paper		
Max. Time: 2 Hrs		Max. Marks: 50

SECTION-I

Answer any THREE questions (Must attempt at least one from each Part). Each question carries 10 Marks. 3X10=30M

PART-A

1. Why is data wrangling important when starting a data pipeline, and how can JavaScript help in this process?
2. Explain how to create different types of Node.js projects
3. What are the main steps involved in parsing JSON and CSV data?

PART-B

4. What is asynchronous coding in Node.js? How do promises help, and how can you handle errors in asynchronous code?.
5. Explain how you can use a reduced data sample and iteration to better understand your data.
6. Describe the steps you would take to clean and prepare a data set so that it is ready for effective use in analysis.

SECTION-II

Answer any FOUR questions. Each question carries 5 Marks. 4X5=20M

7. Why use JavaScript for data wrangling?
8. How do you check your Node.js version?
9. Why do we use promises in Node.js?
10. What is JSON and why is it important for data exchange?
11. Name two databases you can import data from in this topic.
12. What is the purpose of using a reduced data sample during exploratory coding?
13. What does data preparation help improve in a project?

	Pithapur Rajahs Government College(A) Kakinada Department of Computer Science	Program: III B.Sc. (Data Science) Semester : V
Course 15-B	Course Name: Data Wrangling With Java Script Lab	
	Hours Allocated: 2 hrs. /week	Credits: 1

Lab List

1. Installing steps for Node.js, Installing npm dependencies, printing version of Node.js.

Developing a Simple program to print “Hello World” on console.

2. Create a Code library to a command-line application in Node.js to produce a report from data.

3. Install “Express Node.js framework” . Create a simple Web application to print your college name on Web Page.

4. Develop an Web application to add static files to web server.

5. Develop an application to import & export data using MongoDB.

6. Develop an application to import & export data using MYSQL.

7. Loading your input CSV file and printing its contents to the console. Apply slicing operation on data and print on Console. Print datatype of each column(attribute) of CSV file.

8. List column names and data types of column names of a CSV file using Data-Forge (An open source data-wrangling toolkit for JavaScript).

9. Develop a web visualization application by importing data from Excel file.

10. Develop an application to do Excel data analysis in Node.js using Formulajs.

11. Develop a program to clean your data by rewriting rows to fix bad data

Certificate Course in Indian Mathematics & Foundations of Machine Learning

Duration: 30 Hours

Eligibility: Students of AI / Data Science / IoT / CSE

Type: Certificate Course with IKS Component (As per NEP 2020)

1. Course Objectives

By the end of the course, learners will be able to:

1. Understand key ideas from **Indian Mathematics** (number theory, combinatorics, geometry, series methods) and relate them to modern computational thinking.
2. Build strong foundations in **Linear Algebra, Probability, Statistics and Optimization**, essential for Machine Learning.
3. Apply classical mathematical thinking to understand modern **ML algorithms**, including regression, clustering, and PCA.
4. Recognize how traditional Indian approaches to pattern recognition, counting, and approximation inform modern analytics and learning systems.
5. Develop the ability to solve ML problems with mathematical rigor and contextual understanding rooted in India's knowledge systems.

2. Course Outcomes (COs)

After completing the course, students will be able to:

CO1: Explain fundamental concepts from Indian Mathematics and connect them to computational problem-solving.

CO2: Apply essential mathematical tools (linear algebra, probability, optimization) used in AI/ML.

CO3: Demonstrate understanding of ML algorithms such as linear regression, logistic regression, k-means, and PCA.

CO4: Use Indian mathematical techniques (series, approximations, combinatorics) to reason about numerical methods and iterative algorithms.

CO5: Integrate mathematical foundations with machine learning tasks to analyse datasets and derive insights.

Syllabus

UNIT 1: Indian Mathematics & Foundations of ML (6 Hours)

- Historical survey of Indian Mathematics: number theory, combinatorics, geometry.
- Algorithmic thinking in ancient mathematical texts.
- Overview of Machine Learning: supervised vs. unsupervised learning.
- How mathematical thinking forms the foundation for ML.

Unit Outcomes (UO1):

- Understand contributions from Indian Mathematics and map them to modern computational ideas.
- Explain the role of mathematics in ML model building.
- Identify areas where traditional combinatorial and geometric reasoning support ML tasks.

UNIT 2: Indian Mathematics – Number Theory, Combinatorics & Algorithms

- Modular arithmetic, residues, divisibility (Indian number theory tradition).
- Combinatorial counting methods → applications in ML (search, optimization).
- Approximation methods, infinite series, and early Indian trigonometric/geometry approaches.
- Linking Indian algorithms with modern algorithmic principles.

Unit Outcomes (UO2):

- Apply combinatorial and number-theoretic reasoning to algorithmic problems.
- Explain the link between traditional approximation methods and iterative ML solvers.
- Understand how pattern-based mathematical thinking translates into algorithm design.

UNIT 3: Linear Algebra for Machine Learning

- Vectors, matrices, linear transformations, systems of equations.
- Rank, subspaces, orthogonality.
- Eigenvalues, eigenvectors, diagonalization.
- Singular Value Decomposition (SVD).
- Principal Component Analysis (PCA).

Unit Outcomes (UO3):

- Perform matrix operations and understand geometric interpretations.
- Apply eigenvalues/eigenvectors and SVD in dimensionality reduction.
- Relate linear algebra tools directly to ML models such as PCA and regression.

UNIT 4: Probability, Statistics & Optimization for ML

- Probability axioms, Bayes' theorem.
- Random variables and distributions (normal, binomial).
- Joint, marginal, and conditional distributions.
- Covariance, correlation matrices.
- Central Limit Theorem & LLN.
- Gradients, Hessians, gradient descent.
- Constrained optimization (Lagrange multipliers).

Unit Outcomes (UO4):

- Apply probability and statistical concepts to model uncertainty in ML.
- Use covariance and correlation to analyse dataset structure.
- Understand optimization strategies behind ML algorithms such as gradient descent.

UNIT 5: ML Algorithms & Indian Mathematical Perspective

- Supervised learning: Linear Regression, Logistic Regression.
- Unsupervised learning: k-Means, PCA interpretation.
- Indian mathematics insights for pattern recognition and combinatorial reasoning.
- Approximation methods → gradient-based ML methods.
- Case studies, datasets, and mini-project ideas.

Unit Outcomes (UO5):

- Implement basic ML algorithms with mathematical understanding.
- Connect Indian mathematical thinking to modern ML concepts like clustering and pattern recognition.
- Analyse case studies where Indian knowledge principles inspire modern computational models.

4. Pedagogy

- Lectures + hands-on problem solving
- ML demonstrations using Python
- Flipped classroom
- Case studies linking IKS and ML
- Mini-project at the end

5. Assessment Scheme

- Internal Assessment / Assignments – 30M
- Final Examination – 70M

6. Mapping with IKS

This course integrates IKS by:

- Introducing classical Indian mathematical techniques and concepts.
- Linking Indian combinatorics, geometry, series, and algorithmic methods to ML theory.
- Demonstrating how India's historical mathematical advances form part of the conceptual foundation of modern computational thinking.
- Encouraging students to critically compare traditional and modern approaches.

PITHAPUR RAJAH'S GOVERNMENT COLLEGE (A),KAKINADA
DEPARTMENT: COMPUTER SCIENCE
ACADEMIC YEAR:2025-2026

SL.NO	ACTIVITY	UNITS	TIME-LINE
1	SEMINAR/WORKSHOP	1	December
2	MOU'S	2	November
3	CERTIFICATE COURSES	2	Per Year
4	RESEARCH PAPERS	6	Apr-26
5	WEBSITE UPDATION	Up To Date	Up To Date
6	GUEST LECTURES	2	Per Semester One
7	INDUSTRIAL VISIT	1	January
8	EXTENSION LECTURES	1	March
9	STUDENT EXCHANGE PROGRAMS	1	December
10	IMPORTANT DAYS	9	Particular Day
	National IT Professional Day		3rd Tue, September
	World Computer Security day		30th Nov
	World Computer Literacy Day		2nd Dec
	National Technology Day		6th Jan
	World Data Privacy Day		28th Jan
	Safer Internet Day		9th Feb
	National Science Day		28th Feb
	World Backup day		31st Mar
	World IoT Day		9th April